

Form 8607, Revised
(438)
Printed in U. S. A.

LIST OF PARTS



SINGER** MACHINES

Nos. 95-1, 95-2 and
95-10 to 95-12

THE SINGER MANUFACTURING COMPANY

**A Trade Mark of THE SINGER MANUFACTURING COMPANY

From the library of: Diamond Needle Corp

INSTRUCTIONS FOR OILING

To ensure easy running and prevent unnecessary wear of the parts which are in movable contact, the machine requires oiling and when in continuous use, "TYPE B" or "TYPE D" OIL, sold only by Singer Sewing Machine Company, should be applied at least twice each day to all oil holes marked "OIL".

Copyright, U. S. A., 1917, 1921, 1922, 1923, 1928,
1931, 1933 and 1938
by The Singer Manufacturing Company
All Rights Reserved for all Countries

INDEX

	Page
Accessories.....	47
Binder.....	47
Bobbin Winders.....	47
Finger Guards.....	50
Foot Lifter Parts for 52029.....	50
Foot Lifter Parts for 52116.....	51
Hemmers.....	52
Hemmers on Shank.....	54
Knee Lifter Parts for 52030 or 52038.....	55
Knee Lifter Parts for 52117.....	56
Knife Grinder.....	57
Machine Base.....	58
Machine No. 95-1.....	5
Machine No. 95-2.....	14
Machine No. 95-10.....	21
Machine No. 95-11.....	31
Machine No. 95-12.....	39
Numerical List of Parts.....	67
Obsolete Parts.....	62
Piping Attachment.....	58
Presser Feet.....	59
Presser Foot Extensions.....	59
Spool Holder (Disc).....	59
Thread Unwinder.....	60
Tuckers (Long Arm).....	60

From the library of: Diamond Needle Corp

INSTRUCTIONS FOR ORDERING

In ordering from this list, use **ONLY** the part NUMBER in the **FIRST** column.

The number stamped on a Sewing Machine Part is in every case the number of the single part only.

Every combination of parts sent out as such has its specific number, which, although not stamped on the parts, must be used when ordering the combination.

Each number always indicates the **SAME PART** in whatever list it appears, or for whatever machine.

The letters after some of the numbers indicate the style of finish only, as follows:

- A-Hardened, Polished, Nickel Plated and Buffed
- B-Polished, Nickel Plated and Buffed
- C-Hardened Only
- D-Polished Only
- E-Soft, Not Polished
- F-Hardened and Polished
- J-Hardened, Polished and Nickel Plated
- G-Bright Rumbled and Nickel Plated
- H-Blued
- J-Nickel Plated Only
- K-Hardened and Nickel Plated
- L-Brass Plated
- M-Oxidized
- N-Japanned, Dull
- P-Japanned, Bright
- R-Merlized
- S-Cadmium Plating
- T-Copper Plated
- T.A-Hardened, Polished, Copper and Nickel Plated and Buffed
- T.B-Copper and Nickel Plated and Polished
- T.J-Copper and Nickel Plated Only
- T.K-Hardened, Copper and Nickel Plated
- T.L-Copper and Brass Plated
- T.M-Copper Plated and Oxidized
- U-Zinc Plated
- V-Silver Plated
- W-Polished and Nickel Plated
- X-Black Oxide, for Iron and Steel
- X.C-Hardened and Black Oxide, for Iron or Steel
- Y-Black Nickel Plated Only
- Z-Chromium Plated
- Z.A-Hardened, Polished, Nickel Plated, Buffed and Chromium Plated
- Z.B-Polished, Nickel Plated, Buffed and Chromium Plated
- Z.C-Hardened and Chromium Plated
- Z.J-Nickel and Chromium Plated

These letters **MUST BE USED** when they appear in the list; and **AFTER** the number **as** in the list.

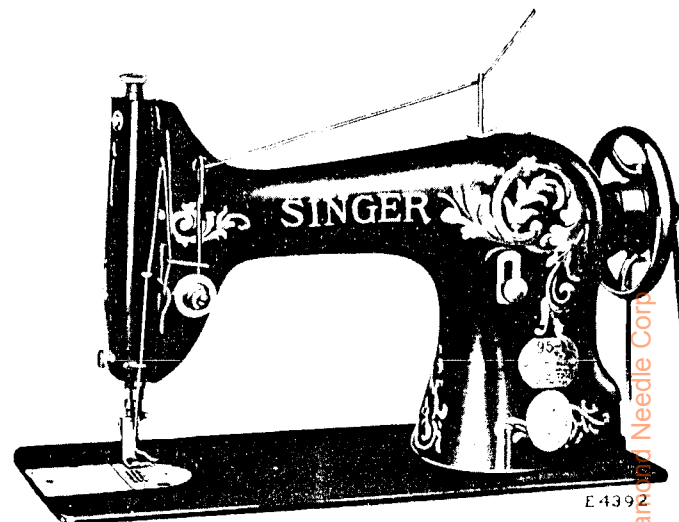
In this series:

- 1 to 1500, 50001 to 51500 and 140001 to 142000 are Screw Numbers
- 1501 to 1800 and 51501 to 51800 are Nut Numbers
- 1801 to 2000 and 51801 to 52000 are Roller Numbers
- 2001 to 50000 and 52001 to 140000 and 142001 to 190000 are Sewing Machine Parts, 190001 and upward are numbers of Electrical Parts.

The figures in the second column refer only to the plates, illustrating the parts, and are **NOT TO BE USED** in ordering.

Parts marked with an asterisk (*) are furnished only when repairs are made at factory.

LIST OF PARTS COMPLETE FOR



MACHINE No. 95-1

FOR LIGHT AND MEDIUM WEIGHT FABRICS.
MAXIMUM STITCH SEVEN TO THE INCH.
DROP FEED. SPEED 3500 R. P. M.

No.	Plate	Name
*52079	-----	Arm with 15404 and two 15405.....
Note: Due to the accuracy required for gear alignment, Arm cannot be supplied separately and can only be sent out as a unit, Arm and Bed assembled.		
16532	5873	Arm Dowel Pin.....
24131	5873	" Oil Tube with 52045, for oiling Feed and Feed Lifting Eccentric Sleeve...
52084	21858	Arm Oil Tube with 52045, for oiling Needle Bar Connecting Link.....
18130	5873	Arm Oil Tube with 52045, for oiling Thread Take-up Lever.....
12454	5873	Arm Oil Tube with 132590, for oiling Thread Take-up Lever Link.....
24131	5873	Arm Oil Tube with 52045, for 52003.....
52002	-----	" " " Holder.....

From the library of: Diana Needle Corp.

No.	Plate	Name
52003	5873	Arm Oil Tube Holder 52002 with 24131, for oiling Feed Lifting Rock Shaft Connecting Rod.....
52045	5871	Arm Oil Tube Packing (wick) for 18130, 24131 and 52084.....
132590	21856	Arm Oil Tube Packing (wick) for 12454....
116E	5875	" Screw (back).....
868E	5875	" " (front).....
52004	5850	" Shaft.....
43921	5850	" " Flanged Bushing (back).....
52146	5922	" " " " " Oil Pad (braided cotton).....
448C	5872	Arm Shaft Flanged Bushing (back) Set Screw.....
52078	5894	Arm Shaft Flanged Bushing (front).....
52146	5922	" " " " " Oil Pad (braided cotton).....
435C	5861	Arm Shaft Flanged Bushing (front) Set Screw.....
144D	5875	Arm Shaft Screw.....
1248C	5850	" Side Cap.....
219J	5875	" " " Screw.....
12193	5870	" " Cover.....
50053D	21855	" " " Thumb Screw.....
12403	5873	" Spool Pin and Thread Eyelet.....
8879	21856	" " " Washer (cloth).....
52005	5850	Balance Wheel (power) light rim, 2 3/16 in. pulley, with two 448C.....
52081	21857	Balance Wheel (stand) heavy rim, 2 11/16 in. pulley, with two 448C.....
24297	5850	Balance Wheel Oil Cover.....
210D	5875	" " " " " Screw.....
448C	5872	" " " " " Set Screw.....
*52006	-----	Bed.....
Note: Due to the accuracy required for gear alignment, Bed cannot be supplied separately and can only be sent out as a unit, Arm and Bed assembled.		
12431	-----	Bed Slide.....
12432	5870	Bed Slide complete, Nos. 4307, 12431 and two 725E.....
4307	5870	Bed Slide Spring.....
725E	5875	" " " " " Screw.....
52051	-----	Face Plate.....
52052	5894	Face Plate complete, Nos. 52051, 52053, 52170 and two 226J.....
190J	5875	Face Plate Screw.....
52053	21858	" " " " " Thread Guard (lower).....
226J	21855	" " " " " " Screw....
52170	21858	" " " " " " (upper).....

No.	Plate	Name
226J	21855	Face Plate Thread Guard (upper) Screw...
50190J	21855	" " " Thumb Screw.....
52452	5916	Feed Bar.....
313C	5875	" " " " " Screw Center.....
56813	-----	" " " " " 313C with 1519J...
1519J	5872	" " " " " Nut.....
52165	21858	" " " " " Connecting Link.....
375C	5852	" " " " " Hinge Screw.....
1519J	5852	" " " " " " Nut....
52031	5856	Feed Dog, for shirt work, 19 teeth (22 teeth to the inch) for 52032 and 52033.....
Note: No. 52031 is sent with this machine unless another Feed Dog is specified on order for 52032 and 52033.		
44144	5854	Feed Dog, beveled for hemmer, 22 teeth (24 teeth to the inch) for 20152 and 20153.....
20162	5855	Feed Dog, for shirt work, beveled for hemmer, 17 teeth (16 teeth to the inch) for 20139 and 20140.....
12450	5855	Feed Dog, for cloth, 11 teeth (18 teeth to the inch) for 20135 and 20136....
44177	5853	Feed Dog, 19 teeth (22 teeth to the inch) for 20148 and 20149.....
20348	5855	Feed Dog, for chiffon, 22 teeth (36 teeth to the inch) for 20135 and 20136.....
20117	5853	Feed Dog, for shirt work, beveled for hemmer, 16 teeth (16 teeth to the inch) for 20124 and 20125.....
20132	5853	Feed Dog, for shirt work, beveled for hemmer, 22 teeth (22 teeth to the inch) for 20124 and 20125.....
20138	5855	Feed Dog, for shirt work, beveled for hemmer, 13 teeth (12 teeth to the inch) for 20139 and 20140.....
20142	5853	Feed Dog, for general work, 13 teeth (16 teeth to the inch) for 20143 and 20144.....
20147	5853	Feed Dog, 12 teeth (14 teeth to the inch) for 20148 and 20149.....
20151	5854	Feed Dog, for shirt work, beveled for hemmer, 13 teeth (14 teeth to the inch) for 20152 and 20153.....
20159	5854	Feed Dog, for shirt work, 16 teeth (16 teeth to the inch) for 20160 and 20161.....
20325	5854	Feed Dog, for shirt work, 17 teeth (16 teeth to the inch) for 20326 and 20327.....

PARTS FOR MACHINE No. 95-1

No.	Plate	Name
44252	5856	Feed Dog, for cloth, 12 teeth (12 teeth to the inch) for 44255 and 44256....
44253	5856	Feed Dog, for cloth, 16 teeth (16 teeth to the inch) for 44255 and 44256....
50117E	5875	Feed Dog Screw.....
24035	5851	" and Feed Lifting Eccentric with 448C.....
448C	5872	Feed and Feed Lifting Eccentric Set Screw.....
24036	5851	Feed and Feed Lifting Eccentric Sleeve..
24037	5851	" Forked Connection.....
375C	5852	" " " Hinge Screw.....
1518J	5852	" " " " Nut..
16504	5851	" Lifting Rock Shaft.....
16588	-----	Feed Lifting Rock Shaft complete, Nos. 3093, 12376, 16504 and 16556.....
12430	5851	Feed Lifting Rock Shaft Connecting Rod with two 966E.....
966E	5889	Feed Lifting Rock Shaft Connecting Rod Cap Screw.....
375C	5852	Feed Lifting Rock Shaft Connecting Rod Hinge Screw.....
1518J	5852	Feed Lifting Rock Shaft Connecting Rod Hinge Screw Nut.....
16556	5852	Feed Lifting Rock Shaft Crank (back) with 462C.....
3093	5917	Feed Lifting Rock Shaft Crank (back) Pin
462C	5852	" " " " " " Set Screw.....
*52271	-----	Feed Lifting Rock Shaft Crank (front)...
12376	5852	" " " " " " 52271 (front) with 157J and 1813.....
157J	5852	Feed Lifting Rock Shaft Crank (front) Clamping Screw.....
1813	5852	Feed Lifting Rock Shaft Crank (front) Roller and Stud.....
307C	5875	Feed Lifting Rock Shaft Screw Center....
56814	-----	" " " " " " 307C with 1513J.....
1513J	5872	Feed Lifting Rock Shaft Screw Center Nut
3039	5852	" Regulator.....
1128E	5852	" " Hinge Screw.....
818D	5852	" " Thumb Screw.....
16506	5851	" Rock Shaft.....
24376	-----	Feed Rock Shaft complete, Nos. 16506 and 29633.....
29633	5852	Feed Rock Shaft Crank with 157J.....
157J	5852	" " " " Clamping Screw....
307C	5875	" " " " Screw Center.....
56814	-----	" " " " " " 307C with 1513J.....

PARTS FOR MACHINE No. 95-1

No.	Plate	Name
1513J	5872	Feed Rock Shaft Screw Center Nut.....
25878	6449	Guide.....
25866	6449	Guide.....
50190W	21855	" Thumb Screw.....
52129	5916	Needle Bar (hollow) with 857C.....
52013	5861	" " Bushing (lower) with 29532...
1133E	5861	" " " " Set Screw....
52014	5861	" " " (upper).....
1133E	5861	" " " " Set Screw....
*24040	5861	" " Connecting Link with 794E....
24894	-----	" " " " 24040 with 24041.....
794E	5861	Needle Bar Connecting Link Adjusting Screw.....
775E	5861	Needle Bar Connecting Link Cap Screw...
24041	5861	" " " Stud with 207E....
207E	2834	" " " " Clamping Screw.....
52015	5851	Needle Bar Crank with 1036C, 1037C and 1065C.....
1065C	5875	Needle Bar Crank Position Screw.....
29532	5861	" " Oil Cup.....
857C	5861	" Set Screw.....
12591	5870	Presser Bar (hollow).....
20059	5852	" " Guide Bracket with 453C.....
453C	5852	" " " " Set Screw....
52016	5852	" " Lifter.....
689C	5852	" " " Hinge Screw.....
1520J	5852	" " " " " " Nut.....
12327	5852	" " " " " " Lifting and Releasing Lever Bracket.....
11167	5870	Presser Bar Spring.....
11170	5873	" " " Washer.....
40315	5886	" Foot, for long stitch, for general work, for 52031.....
Note: No. 40315 is sent with this machine unless another Presser Foot is specified on order.		
12261	5864	Presser Foot for 20162.....
12143	5864	" " " 44252 and 44253.....
12144	5864	" " " 20117, 20132, 20138, 20147, 20151, 20159 and 20162.....
12260	5864	Presser Foot for 12450, 20147 and 20348.
62527	21861	" " Hinge Pin.....
2C344	-----	" " Plate.....
2C345	-----	" " Shark.....
26231	5873	" " Spring.....
20346	5862	Presser Foot (spring hinged) complete for 20117, 20138, 20147, 20151 and 20162, Nos. 20344, 20345, 26231 and 62527.....

From the Library of Diamond Needle Corp.

No.	Plate	Name
7298	5873	Presser Foot Hinge Pin.....
20268	-----	" " Plate.....
20269	-----	" " Shank.....
20270	5862	Presser Foot (hinged) complete for 44252 and 44253, Nos. 7298, 20268 and 20269
62527	21861	Presser Foot Hinge Pin.....
20472	-----	" " Plate.....
20473	-----	" " Shank.....
26231	5873	" " Spring.....
20474	5862	Presser Foot (spring hinged) complete, for fine silk, etc., Nos. 20472, 20473, 26231 and 62527.....
20118	5862	Presser Foot, for general work, for 12450.....
20150	2186C	Presser Foot for 20142.....
20342	21860	" " " 12450 and 20348.....
26276	5873	" " Hinge Pin.....
52034	-----	" " Plate.....
52035	-----	" " Shank.....
52036	21860	Presser Foot (hinged) complete, for 52031, Nos. 26276, 52034 and 52035..
62527	21861	Presser Foot Hinge Pin.....
24544	-----	" " Plate.....
24982	-----	" " Shank.....
26231	5873	" " Spring.....
24983	21860	Presser Foot (spring hinged) complete for 52031, Nos. 24544, 24982, 26231 and 62527.....
190J	5875	Presser Foot Screw.....
688J	5875	Pressure Regulating Thumb Screw.....
52121	-----	Rotating Hook with three 1253C.....
52123	-----	" " 52121 with 52090 and four 1053E.....
52089	5898	Rotating Hook 52123 with 40274 and three 1367E (For agents only).....
52298	-----	Rotating Hook 52123 with 40274, 127242 and three 1367E.....
52299	-----	Rotating Hook 52298 with 52237.....
40258	5870	" " Belt.....
52037	5870	" " " Guard.....
181D	5875	" " " " Screw.....
52048	5888	" " " Pulley (lower, steel) with two 1147C and sixteen 52049....
1147C	5889	Rotating Hook Belt Pulley (lower) Set Screw.....
52049	5888	Rotating Hook Belt Pulley (lower) Stud..
52050	5888	" " " " (upper) with 1362C and thirty 40263.....
1362C	5871	Rotating Hook Belt Pulley (upper) Set Screw.....

No.	Plate	Name
40263	5871	Rotating Hook Belt Pulley (upper) Stud..
40264	5869	" " Bobbin.....
52235	-----	" " " " Case.....
52236	21861	" " " " 52235 with 591F, 1380E and 40394.....
40392	5869	Rotating Hook Bobbin Case Latch.....
125320	21861	" " " " " Lever...
2974	5869	" " " " " " Fulcrum Pin.....
2975	5869	Rotating Hook Bobbin Case Latch Spring..
592E	5869	" " " " " " Stop Screw.....
40393	-----	Rotating Hook Bobbin Case Hinge, Nos. 2974, 40392 and 125320.....
591F	5869	Rotating Hook Bobbin Case Tension Regulating Screw.....
40394	5869	Rotating Hook Bobbin Case Tension Spring
1380E	5869	" " " " " " Screw.....
52237	-----	Rotating Hook Bobbin Case complete, Nos. 592E, 2975, 40393 and 52236.....
127241	-----	Rotating Hook Bobbin Case 52237 with 127242.....
127242	21861	Rotating Hook Bobbin Case Holder.....
52018	5869	" " " " " " Position Bracket.....
704J	5869	Rotating Hook Bobbin Case Holder Position Bracket Screw.....
40274	5869	Rotating Hook Section.....
1367E	5869	" " " " Screw.....
1253C	5869	" " " Set Screw.....
52019	5870	" " " Shaft.....
52044	5871	" " " " Bushing (back)....
52045	5871	" " " " " " Pack- ing (wick).....
447C	5871	Rotating Hook Shaft Bushing (back) Set Screw.....
52039	5871	Rotating Hook Shaft Bushing (front)....
52045	5871	" " " " " " Pack- ing (wick).....
50145E	5889	Rotating Hook Shaft Bushing (front) Position Screw.....
54897	21856	Rotating Hook Shaft Front Bearing Oil Cup.....
52090	5898	Rotating Hook Thread Guard.....
1053E	5869	" " " " " Screw.....
20060	5872	Slack Thread Regulator.....
225F	5872	" " " " Adjusting Screw..
52046	21863	Spool Holder Base.....
389D	5889	" " " " Screw.....

From the files of: Larned Needle Corp.

No.	Plate	Name
204296	21863	Spool Holder Base Wire.....
200079H	5869	" " " " Hinge Screw.....
52047	21863	Spool Holder complete, Nos. 52046, 200079H and 204296.....
2102	3471	Tension Disc.....
1560C	5872	" Regulating Thumb Nut.....
32572	5872	" Releasing Disc.....
43944	5872	" " Lever.....
12398	5872	" " " Hinge Pin.....
12329	5872	" " " Spring.....
32574	5872	" " Pin.....
13710	5872	" Spring.....
50304C	21855	" Stud.....
52098	-----	" " 50304C with 1560C.....
50305C	21855	" " Set Screw.....
52092	-----	Tension complete, Nos. 13710, 32572, 32574, 52082, 52083, 52098 and two 2102....
29642	5872	Thread Eyelet (side of arm).....
52171	21858	" " for 52013.....
480C	5872	" " Set Screw for 29642.....
52027	5872	" Guard (side of arm).....
52054	-----	Thread Take-up complete, Nos. 11204, 52025 and 52143.....
52021	5861	Thread Take-up Crank.....
52143	-----	" " " 52021 with 775E and 24894.....
1037C	5861	Thread Take-up Crank Position Screw.....
1038C	5861	" " " Set Screw.....
52022	5861	" " Lever with 52130.....
52023	5861	" " " Hinge Pin.....
52024	5861	" " " Link.....
11204	5861	" " " " Hinge Pin.....
435C	5861	" " " " " " Set Screw.....
52025	-----	Thread Take-up Lever complete, Nos. 52022 to 52024.....
52130	5917	Thread Take-up Lever Thread Eyelet Bushing.....
52082	21859	Thread Take-up Spring.....
52083	21862	" " " Regulator with 50305C.....
448C	5872	Thread Take-up Spring Regulator Set Screw.....
20139	5855	Throat Plate, large needle hole, for 20138 and 20162.....
20140	-----	Throat Plate, small needle hole, for 20138 and 20162.....
20135	5855	Throat Plate, large needle hole, for 12450 and 20348.....
20136	-----	Throat Plate, small needle hole, for 12450 and 20348.....

No.	Plate	Name
20124	5853	Throat Plate, large needle hole, for 20117 and 20132.....
20125	-----	Throat Plate, small needle hole, for 20117 and 20132.....
20143	5853	Throat Plate, large needle hole, for 20142.....
20144	-----	Throat Plate, small needle hole, for 20142.....
20148	5853	Throat Plate, large needle hole, for 20147 and 44177.....
20149	-----	Throat Plate, small needle hole, for 20147 and 44177.....
20152	5854	Throat Plate, large needle hole, for 20151 and 44144.....
20153	-----	Throat Plate, small needle hole, for 20151 and 44144.....
20160	5854	Throat Plate, large needle hole, for 20159.....
20161	-----	Throat Plate, small needle hole, for 20159.....
20326	5854	Throat Plate, large needle hole, for 20325.....
20327	-----	Throat Plate, small needle hole, for 20325.....
44256	5856	Throat Plate, large needle hole, for 44252 and 44253.....
44255	-----	Throat Plate, small needle hole, for 44252 and 44253.....
52032	-----	Throat Plate, large needle hole, for 52031.....
52033	5856	Throat Plate, small needle hole, for 52031.....
Note: No. 52033 is sent with this machine unless another Throat Plate is specified on order.		
691F	5875	Throat Plate Screw.....
*15404	-----	Trade Mark.....
15405	-----	" " Rivet.....
24079	5877	Drip Pan.....

LIST OF PARTS COMPLETE
FOR

MACHINE No. 95-2

FOR COLLAR AND CUFF WORK. DROP FEED

OBSOLETE

No.	Plate	Name
*52079	-----	Arm with 15404 and two 15405.....
<p>Note: Due to the accuracy required for gear alignment, Arm cannot be supplied separately and can only be sent out as a unit, Arm and Bed assembled.</p>		
16532	5873	Arm Dowel Pin.....
24131	5873	" Oil Tube with 52045, for oiling Feed and Feed Lifting Eccentric Sleeve.....
52084	21858	Arm Oil Tube with 52045, for oiling Needle Bar Connecting Link.....
18130	5873	Arm Oil Tube with 52045, for oiling Thread Take-up Lever.....
12454	5873	Arm Oil Tube with 132590, for oiling Thread Take-up Lever Link.....
24131	5873	Arm Oil Tube with 52045, for 52003.....
52002	-----	" " " Holder.....
52003	5873	" " " " 52002 with 24131, for oiling Feed Lifting Rock Shaft Connecting Rod.....
52045	5871	Arm Oil Tube Packing (wick) for 18130, 24131 and 52084.....
132590	21856	Arm Oil Tube Packing (wick) for 12454..
116E	5875	" Screw (back).....
868E	5875	" " (front).....
52004	5850	" Shaft.....
43921	5850	" " Flanged Bushing (back).....
52146	5922	" " " " Oil Pad (braided cotton).....
448C	5872	Arm Shaft Flanged Bushing (back) Set Screw.....
52078	5894	Arm Shaft Flanged Bushing (front).....
52146	5922	" " " " Oil Pad (braided cotton)

No.	Plate	Name
435C	5861	Arm Shaft Flanged Bushing (front) Set Screw.....
144D	5875	Arm Shaft Screw.....
12480	5850	" Side Cap.....
219J	5875	" " " Screw.....
12193	5870	" " Cover.....
50053D	21855	" " " Thumb Screw.....
12403	5873	" Spool Pin and Thread Eyelet.....
8879	21956	" " " Washer (cloth).....
52005	5850	Balance Wheel (power) light rim, 2 3/16 in. pulley, with two 448C.....
52081	21857	Balance Wheel (stand) heavy rim, 2 11/16 in. pulley, with two 448C.....
24297	5850	Balance Wheel Oil Cover.....
210D	5875	" " " " Screw.....
448C	5872	" " Set Screw.....
*52006	-----	Bed.....
<p>Note: Due to the accuracy required for gear alignment, Bed cannot be supplied separately and can only be sent out as a unit, Arm and Bed assembled.</p>		
12431	-----	Bed Slide.....
12432	5870	Bed Slide complete, Nos. 4307, 12431 and two 725E.....
4307	5870	Bed Slide Spring.....
725E	5875	" " " Screw.....
52051	-----	Face Plate.....
52052	5894	Face Plate complete, Nos. 52051, 52053, 52170 and two 226J.....
190J	5875	Face Plate Screw.....
52053	21858	" " Thread Guard (lower).....
226J	21855	" " " " " Screw..
52170	21858	" " " " (upper).....
226J	21855	" " " " " Screw..
50190J	21855	" " Thumb Screw.....
52452	5916	Feed Bar.....
313C	5875	" " Screw Center.....
56813	-----	" " " " 313C with 1519J..
1519J	5872	" " " " Nut.....
52165	21858	" Connecting Link.....
375C	5852	" " " Hinge Screw.....
1518J	5852	" " " " " Nut...
20163	5857	Feed Dog, for 1/16 in. stitch, 16 teeth (16 teeth to the inch) for 20123...
20164	5857	Feed Dog, for 1/8 in. stitch, 16 teeth (16 teeth to the inch) for 20123...
50117E	5875	Feed Dog Screw.....
24035	5851	" and Feed Lifting Eccentric with 448C.....
448C	5872	Feed and Feed Lifting Eccentric Set Screw.....

No.	Plate	Name
24036	5851	Feed and Feed Lifting Eccentric Sleeve.
24037	5851	" Forked Connection.....
375C	5852	" " " Hinge Screw.....
1518J	5852	" " " " " Nut.
16504	5851	" Lifting Rock Shaft.....
16588	-----	Feed Lifting Rock Shaft complete, Nos. 3093, 12376, 16504 and 16556.....
12430	5851	Feed Lifting Rock Shaft Connecting Rod with two 966E.....
966E	5889	Feed Lifting Rock Shaft Connecting Rod Cap Screw.....
375C	5852	Feed Lifting Rock Shaft Connecting Rod Hinge Screw.....
1518J	5852	Feed Lifting Rock Shaft Connecting Rod Hinge Screw Nut.....
16556	5852	Feed Lifting Rock Shaft Crank (back) with 462C.....
3093	5917	Feed Lifting Rock Shaft Crank (back) Pin.....
462C	5852	Feed Lifting Rock Shaft Crank (back) Set Screw.....
*52271	-----	Feed Lifting Rock Shaft Crank (front)..
12376	5852	" " " " " 52271 (front) with 157J and 1813.....
157J	5852	Feed Lifting Rock Shaft Crank (front) Clamping Screw.....
1813	5852	Feed Lifting Rock Shaft Crank (front) Roller and Stud.....
307C	5875	Feed Lifting Rock Shaft Screw Center...
56814	-----	" " " " " " 307C with 1513J.....
1513J	5872	Feed Lifting Rock Shaft Screw Center Nut.....
3039	5852	Feed Regulator.....
1128E	5852	" " Hinge Screw.....
818D	5852	" " Thumb Screw.....
21351	5852	" " " " Stop.....
16506	5851	" Rock Shaft.....
24376	-----	Feed Rock Shaft complete, Nos. 16506 and 29633.....
29633	5852	Feed Rock Shaft Crank with 157J.....
157J	5852	" " " " Clamping Screw...
307C	5875	" " " Screw Center.....
56814	-----	" " " " " 307C with 1513J.....
1513J	5872	Feed Rock Shaft Screw Center Nut.....
25873	21863	Guide (combination).....
50190W	21855	" Thumb Screw.....
3146	5873	" " Washer.....
52129	5916	Needle Bar (hollow) with 857C.....

No.	Plate	Name
52013	5861	Needle Bar Bushing (lower) with 29532..
1133E	5861	" " " " Set Screw...
52014	5861	" " " (upper).....
1133E	5861	" " " " Set Screw...
*24040	5861	" " Connecting Link with 794E...
24894	-----	" " " " 24040 with 24041.....
794E	5861	Needle Bar Connecting Link Adjusting Screw.....
775E	5861	Needle Bar Connecting Link Cap Screw...
24041	5861	" " " Stud with 207E...
207E	2834	" " " " Clamping Screw.....
52015	5851	Needle Bar Crank with 1036C, 1037C and 1065C.....
1065C	5875	Needle Bar Crank Position Screw.....
29532	5861	" " Oil Cup.....
857C	5861	" Set Screw.....
12391	5870	Presser Bar (hollow).....
20059	5852	" " Guide Bracket with 453C...
453C	5852	" " " Set Screw...
52016	5852	" " Lifter.....
689C	5852	" " " Hinge Screw.....
1520J	5852	" " " " Nut.....
12327	5852	" " Lifting and Releasing Lever Bracket.....
11167	5870	Presser Bar Spring.....
11170	5873	" " Washer.....
12435	5865	" Foot with 228J.....
Note: No. 12435 is sent with this machine unless another Presser Foot is specified on order.		
12462	5866	Presser Foot for 1/8 in. to 1 in. gauges
Note: When ordering No. 12462, give width of turned edge from seam.		
12463	5866	Presser Foot with Strip Guide.....
12335	5865	" " (narrow).....
26276	5873	" " Hinge Pin.....
20133	-----	" " Plate.....
19223	-----	" " Shank.....
20134	5866	Presser Foot (hinged) complete, for 3/16 in. to 1/4 in. gauges, Nos. 19223, 20133 and 26276.....
Note: When ordering No. 20134, give width of turned edge from seam.		
62527	21861	Presser Foot Hinge Pin.....
20155	-----	" " Plate.....
20156	-----	" " Shank.....
20157	5865	Presser Foot (hinged) complete, Nos. 228J, 20155, 20156 and 62527.....
20343	5865	Presser Foot with guide on bottom to the right of needle hole.....

In the Library of Diamond Needle Corp

No.	Plate	Name
26276	5873	Presser Foot Hinge Pin.....
20360	-----	" " Plate.....
19335	-----	" " Shank.....
20361	5866	Presser Foot (hinged) plain bottom complete, Nos. 19335, 20360 and 26276.
190J	5875	Presser Foot Screw.....
688J	5875	Pressure Regulating Thumb Screw.....
52121	-----	Rotating Hook with three 1253C.....
52123	-----	" " 52121 with 52090 and four 1053E.....
52089	5898	Rotating Hook 52123 with 40274 and three 1367E (For agents only)....
52298	-----	Rotating Hook 52123 with 40274, 127242 and three 1367E.....
52299	-----	Rotating Hook 52298 with 52237.....
40258	5870	" " Belt.....
52037	5870	" " " Guard.....
181D	5875	" " " Screw.....
52048	5888	" " " Pulley (lower, steel) with two 1147C and sixteen 52049....
1147C	5889	Rotating Hook Belt Pulley (lower) Set Screw.....
52049	5888	Rotating Hook Belt Pulley (lower) Stud.
52050	5888	" " " " (upper) with 1362C and thirty 40263.....
1362C	5871	Rotating Hook Belt Pulley (upper) Set Screw.....
40263	5871	Rotating Hook Belt Pulley (upper) Stud.
40264	5869	" " Bobbin.....
52235	-----	" " " Case.....
52236	21861	" " " 52235 with 591F, 1380E and 40394.....
40392	5869	Rotating Hook Bobbin Case Latch.....
125320	21861	" " " " " Lever..
2974	5869	" " " " " " Fulcrum Pin.....
2975	5869	Rotating Hook Bobbin Case Latch Spring.
592E	5869	" " " " " " Stop Screw.....
40393	-----	Rotating Hook Bobbin Case Hinge, Nos. 2974, 40392 and 125320.....
591F	5869	Rotating Hook Bobbin Case Tension Regulating Screw.....
40394	5869	Rotating Hook Bobbin Case Tension Spring.....
1380E	5869	Rotating Hook Bobbin Case Tension Spring Screw.....
52237	-----	Rotating Hook Bobbin Case complete, Nos. 592E, 2975, 40393 and 52236.....
127241	-----	Rotating Hook Bobbin Case 52237 with 127242.....

No.	Plate	Name
127242	21861	Rotating Hook Bobbin Case Holder.....
52018	5869	" " " " " " Position Bracket.....
704J	5869	Rotating Hook Bobbin Case Holder Position Bracket Screw.....
40274	5869	Rotating Hook Section.....
1367E	5869	" " " " Screw.....
1253C	5869	" " Set Screw.....
52019	5870	" " Shaft.....
52044	5871	" " " Bushing (back)....
52045	5871	" " " " " " Packing (wick).....
447C	5871	Rotating Hook Shaft Bushing (back) Set Screw.....
52039	5871	Rotating Hook Shaft Bushing (front)....
52045	5871	" " " " " " Packing (wick).....
50145E	5869	Rotating Hook Shaft Bushing (front) Position Screw.....
54897	21856	Rotating Hook Shaft Front Bearing Oil Cup.....
52090	5898	Rotating Hook Thread Guard.....
1053E	5869	" " " " " Screw.....
20060	5872	Slack Thread Regulator.....
225F	5872	" " " " Adjusting Screw.
52046	21863	Spool Holder Base.....
389D	5889	" " " " Screw.....
204296	21863	" " " " Wire.....
200079H	5889	" " " " Hinge Screw.....
52047	21863	Spool Holder complete, Nos. 52046, 200079H and 204296.....
2102	3471	Tension Disc.....
1560C	5872	" Regulating Thumb Nut.....
32572	5872	" Releasing Disc.....
43944	5872	" " Lever.....
1239F	5872	" " " Hinge Pin.....
12329	5872	" " " Spring.....
32574	5872	" " " Pin.....
13710	5872	" Spring.....
50304C	21855	" Stud.....
52098	-----	" " 50304C with 1560C.....
50305C	21855	" " Set Screw.....
52092	-----	Tension complete, Nos. 13710, 32572, 32574, 52082, 52083, 52098 and two 2102.....
29642	5872	Thread Eyelet (side of arm).....
52171	21858	" " for 52013.....
46CC	5872	" " Set Screw for 29642.....
52027	5872	" Guard (side of arm).....
52054	-----	Thread Take-up complete, Nos. 11204, 52025 and 52143.....

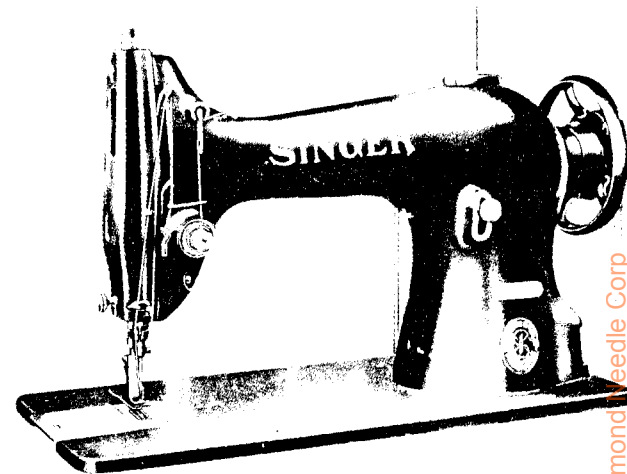
From the Library of Diamond Need Co.

No.	Plate	Name
52021	5861	Thread Take-up Crank.....
52143	-----	" " " 52021 with 775E and 24894.....
1037C	5861	Thread Take-up Crank Position Screw....
1036C	5861	" " " Set Screw.....
52022	5861	" " " Lever with 52130.....
52023	5861	" " " Hinge Pin.....
52024	5861	" " " Link.....
11204	5861	" " " " Hinge Pin....
435C	5861	" " " " " " Set Screw.....
52025	-----	Thread Take-up Lever complete, Nos. 52022 to 52024.....
52130	5917	Thread Take-up Lever Thread Eyelet Bushing.....
52082	21858	Thread Take-up Spring.....
52083	21862	" " " Regulator with 50305C.....
448C	5872	Thread Take-up Spring Regulator Set Screw.....
20123	5857	Throat Plate for 20163 and 20164.....
691F	5875	" " " Screw.....
*15404	-----	Trade Mark.....
15405	-----	" " " Rivet.....
24079	5877	Drip Pan.....

SINGER Needles should be used
in **SINGER** Machines
These Needles and their Containers
are marked with the
Company's Trade Mark "SIMANCO.**" 1

Needles in Containers marked
"FOR SINGER MACHINES"
are NOT **SINGER** made needles. 2

**LIST OF PARTS COMPLETE
FOR**



MACHINE No. 95-10

FOR LIGHT AND MEDIUM WEIGHT FABRICS.
MAXIMUM STITCH SEVEN TO THE INCH.
DROP FEED. SPEED 3500 R. P. M.

From the library of: Diamond Needle Corp

No.	Plate	Name
*52077	-----	Arm with 15404 and two each 15405 and 56015.....
Note: Due to the accuracy required for gear align- ment, Arm cannot be supplied separately and can only be sent out as a unit, Arm and Bed as- sembled.		
16532	5873	Arm Dowel Pin.....
24131	5873	" Oil Tube with 52045, for oiling Feed and Feed Lifting Eccentric Sleeve.....
52084	21858	Arm Oil Tube with 52045, for oiling Needle Bar Connecting Link.....
18130	5873	Arm Oil Tube with 52045, for oiling Thread Take-up Lever.....
12454	5873	Arm Oil Tube with 132590, for oiling Thread Take-up Lever Link.....

No.	Plate	Name
24131	5873	Arm Oil Tube with 52045, for oiling Feed Lifting Rock Shaft Connecting Rod, for 52043.....
52148	5922	Arm Oil Tube for 52149.....
52149	-----	" " " 52148 with 52150, for oiling Arm Shaft (horizontal) Gear....
52150	5922	Arm Oil Tube Packing (braided cotton) for 52149.....
52045	5871	Arm Oil Tube Packing (wick) for 18130, 24131 and 52084.....
132590	21856	Arm Oil Tube Packing (wick) for 12454..
116E	5875	" Screw (back).....
868E	5875	" " (front).....
52141	5916	" Shaft (horizontal).....
52059	5894	" " " Flanged Bushing (back).....
52146	5922	Arm Shaft (horizontal) Flanged Bushing (back) Oil Pad (braided cotton)....
446C	21855	Arm Shaft (horizontal) Flanged Bushing (back) Set Screw.....
52078	5894	Arm Shaft (horizontal) Flanged Bushing (front).....
52146	5922	Arm Shaft (horizontal) Flanged Bushing (front) Oil Pad (braided cotton)....
435C	5861	Arm Shaft (horizontal) Flanged Bushing (front) Set Screw.....
68350	5922	Arm Shaft (horizontal) Front Bearing Oil Cup.....
52060	5898	Arm Shaft (horizontal) Gear with two 1036C.....
52151	5922	Arm Shaft (horizontal) Gear Case (two pieces) with 121E.....
121E	21855	Arm Shaft (horizontal) Gear Case Screw.
1036C	5861	" " " " Set Screw..
144D	5875	" " " " Screw.....
52062	5898	" " (upright).....
56099	5898	" " " Bushing (lower)....
432C	5898	" " " " " Set Screw.....
56100	5898	Arm Shaft (upright) Bushing (upper)....
1149C	5875	" " " " " Set Screw.....
56013	5898	Arm Shaft (upright) Gear (lower) with two 1253C.....
1253C	5869	Arm Shaft (upright) Gear (lower) Set Screw.....
56101	5898	Arm Shaft (upright) Gear (upper) with two 1253C.....
1253C	5869	Arm Shaft (upright) Gear (upper) Set Screw.....

No.	Plate	Name
56015	21858	Arm Shaft (upright) Oil Tube (lower)...
56015	21858	" " " " " (upper)...
12480	5850	" Side Cap.....
219J	5875	" " " Screw.....
12193	5870	" " Cover.....
50053D	21855	" " " Thumb Screw.....
12403	5873	" Spool Pin and Thread Eyelet.....
8879	21856	" " " Washer (cloth).....
52042	21862	" Top Cover.....
52043	-----	" " " 52042 with 12403 and 24131
158D	5889	" " " Screw.....
52005	5850	Balance Wheel (power) light rim, 2 3/16 in. pulley, with two 448C.....
52081	21857	Balance Wheel (stand) heavy rim, 2 11/16 in. pulley, with two 448C....
52063	5894	Balance Wheel Oil Cover.....
210D	5875	" " " " Screw.....
448C	5872	" " Set Screw.....
*52064	-----	Bed.....
Note: Due to the accuracy required for gear alignment, Bed cannot be supplied separately and can only be sent out as a unit, Arm and Bed assembled.		
12431	-----	Bed Slide.....
12432	5870	Bed Slide complete, Nos. 4307, 12431 and two 725E.....
4307	5870	Bed Slide Spring.....
725E	5875	" " " Screw.....
52051	-----	Face Plate.....
52052	5894	Face Plate complete, Nos. 52051, 52053, 52170 and two 226J.....
190J	5875	Face Plate Screw.....
52053	21858	" " Thread Guard (lower).....
226J	21855	" " " " " Screw..
52170	21858	" " " " (upper).....
226J	21855	" " " " " Screw..
50190J	21855	" " Thumb Screw.....
52452	5916	Feed Bar.....
313C	5875	" " Screw Center.....
56813	-----	" " " " 313C with 1519J..
1519J	5872	" " " " Nut.....
52165	21858	" Connecting Link.....
375C	5852	" " " Hinge Screw.....
1518J	5852	" " " " " Nut...
52073	21858	" " " " Stud.....
50083C	21855	" " " " " Set Screw.....

From the library of Blanning Needle Corp.

No.	Plate	Name
52031	5856	Feed Dog, for shirt work, 19 teeth (22 teeth to the inch) for 52032 and 52033.....
Note: No. 52031 is sent with this machine unless another Feed Dog is specified on order.		
44144	5854	Feed Dog, beveled for hemmer, 22 teeth (24 teeth to the inch) for 20152 and 20153.....
20162	5855	Feed Dog, for shirt work, beveled for hemmer, 17 teeth (16 teeth to the inch) for 20139 and 20140.....
12450	5855	Feed Dog, for cloth, 11 teeth (18 teeth to the inch) for 20135 and 20136...
44177	5853	Feed Dog, 19 teeth (22 teeth to the inch) for 20148 and 20149.....
20348	5855	Feed Dog, for chiffon, 22 teeth (36 teeth to the inch) for 20135 and 20136.....
20117	5853	Feed Dog, for shirt work, beveled for hemmer, 16 teeth (16 teeth to the inch) for 20124 and 20125.....
20132	5853	Feed Dog, for shirt work, beveled for hemmer, 22 teeth (22 teeth to the inch) for 20124 and 20125.....
20138	5855	Feed Dog, for shirt work, beveled for hemmer, 13 teeth (12 teeth to the inch) for 20139 and 20140.....
20142	5853	Feed Dog, for general work, 13 teeth (16 teeth to the inch) for 20143 and 20144.....
20147	5853	Feed Dog, 12 teeth (14 teeth to the inch) for 20148 and 20149.....
20151	5854	Feed Dog, for shirt work, beveled for hemmer, 13 teeth (14 teeth to the inch) for 20152 and 20153.....
20159	5854	Feed Dog, for shirt work, 16 teeth (16 teeth to the inch) for 20160 and 20161.....
20325	5854	Feed Dog, for shirt work, 17 teeth (16 teeth to the inch) for 20326 and 20327.....
44252	5856	Feed Dog, for cloth, 12 teeth (12 teeth to the inch) for 44255 and 44256...
44253	5856	Feed Dog, for cloth, 16 teeth (16 teeth to the inch) for 44255 and 44256
52159	5905	Feed Dog, for sheer material, 23 teeth (22 teeth to the inch) for 52160...
50117E	5875	Feed Dog Screw.....
52137	5917	" and Feed Lifting Eccentric with 448C and 1299C.....

No.	Plate	Name
1299C	5917	Feed and Feed Lifting Eccentric Position Screw.....
448C	5872	Feed and Feed Lifting Eccentric Set Screw.....
24036	5851	Feed and Feed Lifting Eccentric Sleeve.
24037	5851	" Forked Connection.....
375C	5852	" " " Hinge Screw.....
1518J	5852	" " " " " Nut.
52065	5895	" Lifting Rock Shaft.....
52066	-----	Feed Lifting Rock Shaft complete, Nos. 12376 and 52065.....
12430	5851	Feed Lifting Rock Shaft Connecting Rod with two 966E.....
966E	5889	Feed Lifting Rock Shaft Connecting Rod Cap Screw.....
375C	5852	Feed Lifting Rock Shaft Connecting Rod Hinge Screw.....
1518J	5852	Feed Lifting Rock Shaft Connecting Rod Hinge Screw Nut.....
*52271	-----	Feed Lifting Rock Shaft Crank.....
12376	5852	" " " " " 52271 with 157J and 1813.....
157J	5852	Feed Lifting Rock Shaft Crank Clamping Screw.....
1813	5852	Feed Lifting Rock Shaft Crank Roller and Stud.....
50191C	21855	Feed Lifting Rock Shaft Screw Center...
1513J	5872	" " " " " " Nut
52074	21863	" Regulator with 50083C.....
1128E	5852	" " Hinge Screw.....
818D	5852	" " Thumb Screw.....
52068	5895	" Rock Shaft.....
52069	-----	Feed Rock Shaft complete, Nos. 29633 and 52068.....
29633	5852	Feed Rock Shaft Crank with 157J.....
157J	5852	" " " " Clamping Screw...
50191C	21855	" " " Screw Center.....
1513J	5872	" " " " " Nut.....
25878	6449	Guide.....
50190W	21855	" Thumb Screw.....
52129	5916	Needle Bar (hollow) with 857C.....
52013	5861	" " Bushing (lower) with 29532..
1133E	5861	" " " " Set Screw...
52014	5861	" " " (upper).....
1133E	5861	" " " " Set Screw...
*24040	5861	" " Connecting Link with 794E...
24894	-----	" " " " 24040 with 24041.....
794E	5861	Needle Bar Connecting Link Adjusting Screw.....

No.	Plate	Name
775E	5861	Needle Bar Connecting Link Cap Screw...
24041	5861	" " " Stud with 207E...
207E	2834	" " " " Clamping Screw.....
52015	5851	Needle Bar Crank with 1036C, 1037C and 1065C.....
1065C	5875	Needle Bar Crank Position Screw.....
29532	5861	" " Oil Cup.....
857C	5861	" Set Screw.....
12391	5870	Presser Bar (hollow).....
52338	21862	" " Guide Bracket with 223C and 453C.....
453C	5852	Presser Bar Guide Bracket Set Screw....
52016	5852	" " Lifter.....
689C	5852	" " " Hinge Screw.....
1520J	5852	" " " " " Nut.....
12327	5852	" " Lifting and Releasing Lever Bracket.....
11167	5870	Presser Bar Spring.....
11170	5873	" " Washer.....
40315	5886	Presser Foot, for long stitch for gen- eral work, for 52031.....
Note: No. 40315 is sent with this machine unless another Presser Foot is specified on order.		
12261	5864	Presser Foot for 20162.....
12143	5864	" " " 44252 and 44253.....
12144	5864	" " " 20117, 20132, 20138, 20138, 20147, 20151, 20159 and 20162.....
52161	5905	Presser Foot for sheer material for 52159.....
12260	5864	Presser Foot for 12450, 20147 and 20348
62527	21861	" " Hinge Pin.....
20344	-----	" " Plate.....
20345	-----	" " Shank.....
26231	5873	" " Spring.....
20346	5862	Presser Foot (spring hinged) complete, for 20117, 20138, 20147, 20151 and 20162, Nos. 20344, 20345, 26231 and 62527.....
7298	5873	Presser Foot Hinge Pin.....
20268	----	" " Plate.....
20269	-----	" " Shank.....
20270	5862	Presser Foot (hinged) complete, for 44252 and 44253, Nos. 7298, 20268 and 20269.....
62527	21861	Presser Foot Hinge Pin.....
20472	-----	" " Plate.....
20473	-----	" " Shank.....
26231	5873	" " Spring.....

No.	Plate	Name
20474	5862	Presser Foot (spring hinged) complete, for fine silk, etc. Nos. 20472, 20473, 26231 and 62527.....
20118	5862	Presser Foot, for general work, for 12450.....
20150	21860	Presser Foot for 20142.....
20342	21860	" " " 12450 and 20348.....
26276	5873	" " Hinge Pin.....
52034	-----	" " Plate.....
52035	-----	" " Shank.....
52036	21860	Presser Foot (hinged) complete for 52031, Nos. 26276, 52034 and 52035.
190J	5875	Presser Foot Screw.....
688J	5875	Pressure Regulating Thumb Screw.....
52121	-----	Rotating Hook with three 1253C.....
52123	-----	" " 52121 with 52090 and four 1053E.....
52089	5898	Rotating Hook 52123 with 40274 and three 1367E (For agents only)....
52298	-----	Rotating Hook 52123 with 40274, 12242 and three 1367E.....
52299	-----	Rotating Hook 52298 with 52237.....
40264	5869	" " Bobbin.....
52235	-----	" " " Case.....
52236	21861	" " " " 52235 with 591F, 1380E and 40394.....
40392	5869	Rotating Hook Bobbin Case Latch.....
125320	21861	" " " " " Lever..
2974	5869	" " " " " Fulcrum Pin.....
2975	5869	Rotating Hook Bobbin Case Latch Spring.
592E	5869	" " " " " Stop Screw.....
40393	-----	Rotating Hook Bobbin Case Hinge, Nos. 2974, 40392 and 125320.....
591F	5869	Rotating Hook Bobbin Case Tension Regu- lating Screw.....
40394	5869	Rotating Hook Bobbin Case Tension Spring.....
1380E	5869	Rotating Hook Bobbin Case Tension Spring Screw.....
52237	-----	Rotating Hook Bobbin Case complete, Nos. 592E, 2975, 40393 and 52236.....
127241	-----	Rotating Hook Bobbin Case 52237 with 127242.....
127242	21861	Rotating Hook Bobbin Case Holder.....
52018	5869	" " " " " Posi- tion Bracket.....
704J	5869	Rotating Hook Bobbin Case Holder Posi- tion Bracket Screw.....

No.	Plate	Name
40274	5869	Rotating Hook Section.....
1387E	5869	" " " " Screw.....
1253C	5869	" " " " Set Screw.....
52070	5895	" " " " Shaft.....
56106	5898	" " " " Bushing (back)....
52045	5871	" " " " " " Pack- ing (wick).....
1143C	5917	Rotating Hook Shaft Bushing (back) Set Screw.....
*56107	5898	Rotating Hook Shaft Bushing (front)....
52045	5871	" " " " " " Pack- ing (wick).....
1148C	5871	Rotating Hook Shaft Bushing (front) Set Screw.....
54897	21856	Rotating Hook Shaft Front Bearing Oil Cup.....
56013	5898	Rotating Hook Shaft Gear with two 1253C
52072	5894	" " " " " " Case (two pieces) with 121E and 50234E.....
50234E	21855	Rotating Hook Shaft Gear Case Plug Screw.....
121E	21855	Rotating Hook Shaft Gear Case Screw....
1253C	5869	" " " " " " Set Screw....
52090	5898	" " " " " " Thread Guard.....
1053E	5869	" " " " " " Screw.....
52337	21863	Slack Thread Regulator.....
223C	21855	" " " " " " Set Screw.....
2102	3471	Tension Disc.....
1560C	5872	" " " " " " Regulating Thumb Nut.....
32572	5872	" " " " " " Releasing Disc.....
43944	5872	" " " " " " Lever.....
12398	5872	" " " " " " Hinge Pin.....
12329	5872	" " " " " " Spring.....
32574	5872	" " " " " " Pin.....
13710	5872	" " " " " " Spring.....
50304C	21855	" " " " " " Stud.....
52098	-----	" " " " " " 50304C with 1560C.....
50305C	21855	" " " " " " Set Screw.....
52092	-----	Tension complete, Nos. 13710, 32572, 32574, 52082, 52083, 52098 and two 2102.....
52171	21858	Thread Eyelet for 52013.....
52027	5872	Thread Guard (side of arm).....
52454	5917	" " " " " " Retainer.....
624C	5922	" " " " " " Set Screw.....
52054	-----	Thread Take-up complete, Nos. 11204, 52025 and 52143.....
52021	5861	Thread Take-up Crank.....
52143	-----	" " " " " " 52021 with 775E and 24894.....

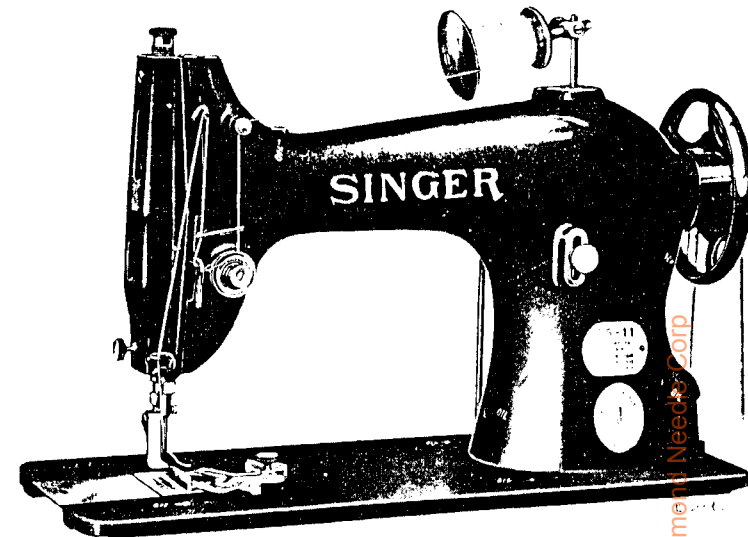
No.	Plate	Name
1037C	5861	Thread Take-up Crank Position Screw....
1036C	5861	" " " " " " Set Screw.....
52022	5861	" " " " " " Lever with 52130.....
52023	5861	" " " " " " Hinge Pin.....
52024	5861	" " " " " " Link.....
11204	5861	" " " " " " Hinge Pin....
435C	5861	" " " " " " " " Set Screw.....
52025	-----	Thread Take-up Lever complete, Nos. 52022 to 52024.....
52130	5917	Thread Take-up Lever Thread Eyelet Bushings.....
52082	21858	Thread Take-up Spring.....
52083	21862	" " " " " " Regulator with 50305C.....
448C	5872	Thread Take-up Spring Regulator Set Screw.....
20139	5855	Throat Plate, large needle hole, for 20138 and 20162.....
20140	-----	Throat Plate, small needle hole, for 20138 and 20162.....
20135	5855	Throat Plate, large needle hole, for 12450 and 20348.....
20136	-----	Throat Plate, small needle hole, for 12450 and 20348.....
20124	5853	Throat Plate, large needle hole, for 20117 and 20132.....
20125	-----	Throat Plate, small needle hole, for 20117 and 20132.....
20143	5853	Throat Plate, large needle hole, for 20142.....
20144	-----	Throat Plate, small needle hole, for 20142.....
20148	5853	Throat Plate, large needle hole, for 20147 and 44177.....
20149	-----	Throat Plate, small needle hole, for 20147 and 44177.....
20152	5854	Throat Plate, large needle hole, for 20151 and 44144.....
20153	-----	Throat Plate, small needle hole, for 20151 and 44144.....
20160	5854	Throat Plate, large needle hole, for 20159.....
20161	-----	Throat Plate, small needle hole, for 20159.....
20326	5854	Throat Plate, large needle hole, for 20325.....
20327	-----	Throat Plate, small needle hole, for 20325.....
44256	5856	Throat Plate, large needle hole, for 44252 and 44253.....

No.	Plate	Name
44255	-----	Throat Plate, small needle hole, for 44252 and 44253.....
52160	5905	Throat Plate, for sheer material, for 52159.....
52032	-----	Throat Plate, large needle hole, for 52031.....
52033	5856	Throat Plate, small needle hole, for 52031.....
Note: No. 52033 is sent with this machine unless another Throat Plate is specified on order.		
691F	5875	Throat Plate Screw.....
*15404	-----	Trade Mark.....
15405	-----	" " Rivet.....
24079	5877	Drip Pan.....

SINGER Needles should be used
in SINGER Machines
These Needles and their Containers
are marked with the
Company's Trade Mark "SIMANCO.**" 1

Needles in Containers marked
"FOR SINGER MACHINES"
are NOT SINGER made needles. 2

LIST OF PARTS COMPLETE
FOR



MACHINE No. 95-II
FOR COLLAR AND CUFF WORK. DROP
FEED. SPEED 3500 R. P. M.

No.	Plate	Name
*52077	-----	Arm with 15404 and two each 15405 and 56015.....

Note: Due to the accuracy required for gear alignment, Arm cannot be supplied separately and can only be sent out as a unit, Arm and Bed assembled.

16532	5873	Arm Dowel Pin.....
24131	5873	" Oil Tube with 52045, for oiling Feed and Feed Lifting Eccentric Sleeve.....
52084	21858	Arm Oil Tube with 52045, for oiling Needle Bar Connecting Link.....
18130	5873	Arm Oil Tube with 52045, for oiling Thread Take-up Lever.....
12454	5873	Arm Oil Tube with 132590, for oiling Thread Take-up Lever Link.....
24131	5873	Arm Oil Tube with 52045, for oiling Feed Lifting Rock Shaft Connecting Rod, for 52043.....

No.	Plate	Name
52148	5922	Arm Oil Tube for 52149.....
52149	-----	" " " 52148 with 52150, for oil- ing Arm Shaft (horizontal) Gear....
52150	5922	Arm Oil Tube Packing (braided cotton) for 52149.....
52045	5871	Arm Oil Tube Packing (wick) for 18130, 24131 and 52084.....
132590	21856	Arm Oil Tube Packing (wick) for 12454..
116E	5875	Arm Screw (back).....
868E	5875	" " (front).....
52141	5916	" Shaft (horizontal).....
52059	5894	" " " Flanged Bushing (back).....
52146	5922	Arm Shaft (horizontal) Flanged Bushing (back) Oil Pad (braided cotton)....
446C	21855	Arm Shaft (horizontal) Flanged Bushing (back) Set Screw.....
52078	5894	Arm Shaft (horizontal) Flanged Bushing (front).....
52146	5922	Arm Shaft (horizontal) Flanged Bushing (front) Oil Pad (braided cotton)...
435C	5861	Arm Shaft (horizontal) Flanged Bushing (front) Set Screw.....
68350	5922	Arm Shaft (horizontal) Front Bearing Oil Cup.....
52060	5898	Arm Shaft (horizontal) Gear with two 1036C.....
52151	5922	Arm Shaft (horizontal) Gear Case (two pieces) with 121E.....
121E	21855	Arm Shaft (horizontal) Gear Case Screw.
1036C	5861	" " " " Set Screw..
144D	5875	" " " " Screw.....
52062	5898	" " (upright).....
56099	5898	" " " Bushing (lower)....
432C	5898	" " " " " Set Screw.....
56100	5898	Arm Shaft (upright) Bushing (upper)....
1149C	5875	" " " " " Set Screw.....
56013	5898	Arm Shaft (upright) Gear (lower) with two 1253C.....
1253C	5869	Arm Shaft (upright) Gear (lower) Set Screw.....
56101	5898	Arm Shaft (upright) Gear (upper) with two 1253C.....
1253C	5869	Arm Shaft (upright) Gear (upper) Set Screw.....
56015	21858	Arm Shaft (upright) Oil Tube (lower)...
56015	21858	" " " " " (upper)...
12480	5850	" Side Cap.....

No.	Plate	Name
219J	5875	Arm Side Cap Screw.....
12193	5870	" " Cover.....
50053D	21855	" " " Thumb Screw.....
12403	5873	" Spool Pin and Thread Eyelet.....
8879	21856	" " " Washer (cloth).....
52042	21862	" Top Cover.....
52043	-----	" " " 52042 with 12403 and 24131.....
15ED	5889	Arm Top Cover Screw.....
52005	5850	Balance Wheel (power) light rim, 2 3/16 in. pulley, with two 448C.....
52081	21857	Balance Wheel (stand) heavy rim, 2 11/16 in. pulley, with two 448C....
52063	5894	Balance Wheel Oil Cover.....
210D	5875	" " " " Screw.....
448C	5872	" " " Set Screw.....
*52064	-----	Bed.....
Note: Due to the accuracy required for gear align- ment, Bed Cannot be supplied separately and can only be sent out as a unit, Arm and Bed as- sembled.		
12431	-----	Bed Slide
12432	5870	Bed Slide complete, Nos. 4307, 12431 and two 725E.....
4307	5870	Bed Slide Spring.....
725E	5875	" " " Screw.....
52051	-----	Face Plate.....
52052	5894	Face Plate complete, Nos. 52051, 52053, 52170 and two 226J.....
190J	5875	Face Plate Screw.....
52053	21858	" " Thread Guard (lower).....
226J	21855	" " " " " Screw..
52170	21858	" " " " (upper).....
226J	21855	" " " " " Screw..
50190J	21855	" " Thumb Screw.....
52452	5916	Feed Bar.....
313C	5875	" " Screw Center.....
56813	-----	" " " " 313C with 1519J..
1519J	5872	" " " " Nut.....
52165	21858	" Connecting Link.....
375C	5852	" " " Hinge Screw.....
1518J	5852	" " " " Nut...
52073	21858	" " " " Stud.....
50083C	21855	" " " " " Set Screw.....
20163	5857	Feed Dog, for 1/16 in. stitch, 16 teeth (16 teeth to the inch) for 20123...
20164	5857	Feed Dog, for 1/8 in. stitch, 16 teeth (16 teeth to the inch) for 20123...
50117E	5875	Feed Dog Screw.....

No.	Plate	Name
52137	5917	Feed and Feed Lifting Eccentric with 448C and 1299C.....
1299C	5917	Feed and Feed Lifting Eccentric Position Screw.....
448C	5872	Feed and Feed Lifting Eccentric Set Screw.....
24036	5851	Feed and Feed Lifting Eccentric Sleeve..
24037	5851	" Forked Connection.....
375C	5852	" " " Hinge Screw.....
1518J	5852	" " " " Nut..
52065	5895	" Lifting Rock Shaft.....
52066	-----	Feed Lifting Rock Shaft complete, Nos. 12376 and 52065.....
12430	5851	Feed Lifting Rock Shaft Connecting Rod with two 966E.....
966E	5889	Feed Lifting Rock Shaft Connecting Rod Cap Screw.....
375C	5852	Feed Lifting Rock Shaft Connecting Rod Hinge Screw.....
1518J	5852	Feed Lifting Rock Shaft Connecting Rod Hinge Screw Nut.....
*52271	-----	Feed Lifting Rock Shaft Crank.....
12376	5852	" " " " 52271 with 157J and 1813.....
157J	5852	Feed Lifting Rock Shaft Crank Clamping Screw.....
1813	5852	Feed Lifting Rock Shaft Crank Roller and Stud.....
50191C	21855	Feed Lifting Rock Shaft Screw Center....
1513J	5872	" " " " " Nut
52074	21863	" Regulator with 50083C.....
1128E	5852	" " Hinge Screw.....
818D	5852	" " Thumb Screw.....
21351	5852	" " " " Stop.....
52068	5895	" Rock Shaft.....
52069	-----	Feed Rock Shaft complete, Nos. 29633 and 52068.....
29633	5852	Feed Rock Shaft Crank with 157J.....
157J	5852	" " " " Clamping Screw....
50191C	21855	" " " " Screw Center.....
1513J	5872	" " " " " Nut.....
25873	21863	Guide (combination).....
50190W	21855	" Thumb Screw.....
3146	5873	" " Washer.....
52129	5916	Needle Bar (hollow) with 857C.....
52013	5861	" " Bushing (lower) with 29532...
1133E	5861	" " " " Set Screw....
52014	5861	" " " (upper).....
1133E	5861	" " " " Set Screw....
*24040	5861	" " Connecting Link with 794E....

No.	Plate	Name
24894	-----	Needle Bar Connecting Link 24040 with 24041.....
794E	5861	Needle Bar Connecting Link Adjusting Screw.....
775E	5861	Needle Bar Connecting Link Cap Screw....
24041	5861	" " " Stud with 207E....
207E	2834	" " " " Clamping Screw.....
52015	5851	Needle Bar Crank with 1036C, 1037C and 1065C.....
1065C	5875	Needle Bar Crank Position Screw.....
29532	5861	" " Oil Cup.....
857C	5861	" Set Screw.....
12391	5870	Presser Bar (hollow).....
52338	21862	" " Guide Bracket with 223C and 453C.....
453C	5852	Presser Bar Guide Bracket Set Screw....
52016	5852	" " Lifter.....
689C	5852	" " " Hinge Screw.....
1520J	5852	" " " " Nut.....
12327	5852	" " Lifting and Releasing Lever Bracket.....
11167	5870	Presser Bar Spring.....
11170	5873	" " " Washer.....
12435	5865	" Foot with 228J.....
Note: No. 12435 is sent with this machine unless another Presser Foot is specified on order.		
12462	5866	Presser Foot for 1/8 in. to 1 in. gauges
Note: When ordering No. 12462, give width of turned edge from seam.		
12463	5866	Presser Foot with Strip Guide.....
12335	5865	" " (narrow).....
26276	5873	" " Hinge Pin.....
20133	-----	" " Plate.....
19223	-----	" " Shank.....
20134	5866	Presser Foot (hinged) complete, for 3/16 in. to 1/4 in. gauges, Nos. 19223, 20133 and 26276.....
Note: When ordering No. 20134, give width of turned edge from seam.		
62527	21861	Presser Foot Hinge Pin.....
20155	-----	" " Plate.....
20156	-----	" " Shank.....
20157	5865	Presser Foot (hinged) complete, Nos. 228J, 20155, 20156 and 62527.....
20343	5865	Presser Foot with guide on bottom to the right of needle hole.....
26276	5873	Presser Foot Hinge Pin.....
20360	-----	" " Plate.....
19335	-----	" " Shank.....

From the Harry Diamond Needle Corp

No.	Plate	Name
20361	5866	Presser Foot (hinged) plain bottom complete, Nos. 19335, 20360 and 26276..
36574	5945	Presser Foot.....
36575	5945	" " 36574 with 36576 and two 50202J.....
36576	5945	Presser Foot Finger Guard.....
50202J	5945	" " " " Screw.....
190J	5875	" " Screw.....
688J	5875	Pressure Regulating Thumb Screw.....
52121	-----	Rotating Hook with three 1253C.....
52123	-----	" " 52121 with 52090 and four 1053E.....
52089	5898	Rotating Hook 52123 with 40274 and three 1367E (For agents only).....
52298	-----	Rotating Hook 52123 with 40274, 127242 and three 1367E.....
52299	-----	Rotating Hook 52298 with 52237.....
40264	5869	" " Bobbin.....
52235	-----	" " " Case.....
52236	21861	" " " " 52235 with 591F, 1380E and 40394.....
40392	5869	Rotating Hook Bobbin Case Latch.....
125320	21861	" " " " " Lever...
2974	5869	" " " " " " Fulcrum Pin.....
2975	5869	Rotating Hook Bobbin Case Latch Spring..
592E	5869	" " " " " Stop Screw.....
40393	-----	Rotating Hook Bobbin Case Hinge, Nos. 2974, 40392 and 125320.....
591F	5869	Rotating Hook Bobbin Case Tension Regulating Screw.....
40394	5869	Rotating Hook Bobbin Case Tension Spring
1380E	5869	" " " " " " Screw.....
52237	-----	Rotating Hook Bobbin Case complete, Nos. 592E, 2975, 40393 and 52236.....
127241	-----	Rotating Hook Bobbin Case 52237 with 127242.....
127242	21861	Rotating Hook Bobbin Case Holder.....
52018	5869	" " " " " Position Bracket.....
704J	5869	Rotating Hook Bobbin Case Holder Position Bracket Screw.....
40274	5869	Rotating Hook Section.....
1367E	5869	" " " Screw.....
1253C	5869	" " Set Screw.....
52070	5895	" " Shaft.....
56106	5898	" " Bushing (back).....
52045	5871	" " " " Pack- ing (wick).....

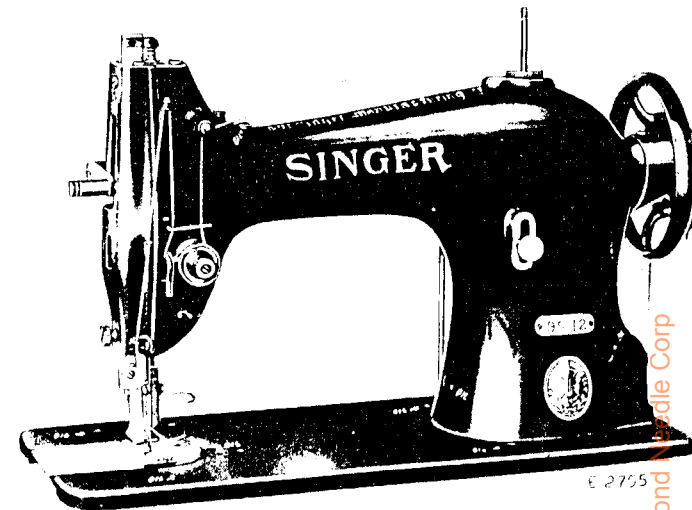
No.	Plate	Name
1143C	5917	Rotating Hook Shaft Bushing (back) Set Screw.....
*56107	5898	Rotating Hook Shaft Bushing (front).....
52045	5871	" " " " " Pack- ing (wick).....
1148C	5871	Rotating Hook Shaft Bushing (front) Set Screw.....
54897	21856	Rotating Hook Shaft Front Bearing Oil Cup.....
56013	5898	Rotating Hook Shaft Gear with two 1253C.
52072	5894	" " " " Case (two pieces) with 121E and 50234E.....
50234E	21855	Rotating Hook Shaft Gear Case Plug Screw
121E	21855	" " " " " Screw.....
1253C	5869	" " " " Set Screw.....
52090	5898	" " Thread Guard.....
1053E	5869	" " " " Screw.....
52337	21863	Slack Thread Regulator.....
223C	21855	" " " Set Screw.....
2102	3471	Tension Disc.....
1560C	5872	" Regulating Thumb Nut.....
32572	5872	" Releasing Disc.....
43944	5872	" " Lever.....
12398	5872	" " " Hinge Pin.....
12329	5872	" " " Spring.....
32574	5872	" " Pin.....
13710	5872	" Spring.....
50304C	21855	" Stud.....
52098	-----	" " 50304C with 1560C.....
50305C	21855	" " Set Screw.....
52092	-----	Tension complete, Nos. 13710, 32572, 32574, 52082, 52083, 52098 and two 2102...
52171	21858	Thread Eyelet for 52013.....
52027	5872	" Guard (side of arm).....
52454	5917	" Retainer.....
624C	5922	" " Set Screw.....
52054	-----	Thread Take-up complete, Nos. 11204, 52025 and 52143.....
52021	5861	Thread Take-up Crank.....
52143	-----	" " " 52021 with 775E and 24894.....
1037C	5861	Thread Take-up Crank Position Screw.....
1036C	5861	" " " Set Screw.....
52022	5861	" " Lever with 52130.....
52023	5861	" " Hinge Pin.....
52024	5861	" " Link.....
11204	5861	" " " Hinge Pin.....
435C	5861	" " " " " Set Screw.....
52025	-----	Thread Take-up Lever complete, Nos. 52022 to 52024.....

No.	Plate	Name
52130	5917	Thread Take-up Lever Thread Eyelet Bushing.....
52082	21858	Thread Take-up Spring.....
52083	21862	" " " Regulator with 50305C.....
448C	5872	Thread Take-up Spring Regulator Set Screw.....
20123	5857	Throat Plate for 20163 and 20164.....
691F	5875	" " Screw.....
*15404	-----	Trade Mark.....
15405	-----	" " Rivet.....
24079	5877	Drip Pan.....

SINGER Needles should be used
in SINGER Machines
These Needles and their Containers
are marked with the
Company's Trade Mark "SIMANCO.**" 1

Needles in Containers marked
"FOR SINGER MACHINES"
are NOT SINGER made needles. 2

LIST OF PARTS COMPLETE
FOR



MACHINE No. 95-12

For Light and Medium Weight Fabrics. Has vertical trimmer that trims from 1/16 to 1/4 inch from the line of stitching. Maximum stitch seven to the inch. Drop Feed. Machines are fitted with 1/8 inch cutting bar unless otherwise ordered, and an extra 3/16 inch cutting bar and presser foot are also furnished. When a different width is ordered the extra cutting bar will be one size larger except when 1/4 inch is required. Speed 3500 R. P. M.

No.	Plate	Name
*52100	-----	Arm with 15404 and two each 15405 and 56015.....

Note: Due to the accuracy required for gear alignment, Arm cannot be supplied separately and can only be sent out as a unit, Arm and Bed assembled.

16532	5873	Arm Dowel Pin.....
24131	5873	" Oil Tube with 52045, for oiling Feed and Feed Lifting Eccentric Sleeve...
52084	21858	Arm Oil Tube with 52045, for oiling Needle Bar Connecting Link.....
18130	5873	Arm Oil Tube with 52045, for oiling Thread Take-up Lever.....

No.	Plate	Name
12454	5873	Arm Oil Tube with 132590, for oiling Thread Take-up Lever Link.....
24131	5873	Arm Oil Tube with 52045, for oiling Feed Lifting Rock Shaft Connecting Rod, for 52043.....
52148	5922	Arm Oil Tube for 52149.....
52149	-----	" " " 52148 with 52150, for oiling Arm Shaft (horizontal) Gear.....
52150	5922	Arm Oil Tube Packing (braided cotton) for 52149.....
52045	5871	Arm Oil Tube Packing (wick) for 18130, 24131 and 52084.....
132590	21856	Arm Oil Tube Packing (wick) for 12454...
116E	5875	Arm Screw (back).....
868E	5875	" " (front).....
52101	21857	" Shaft (horizontal).....
52059	5894	" " " Flanged Bushing (back).....
52146	5922	Arm Shaft (horizontal) Flanged Bushing (back) Oil Pad (braided cotton)....
446C	21855	Arm Shaft (horizontal) Flanged Bushing (back) Set Screw.....
52078	5894	Arm Shaft (horizontal) Flanged Bushing (front).....
52146	5922	Arm Shaft (horizontal) Flanged Bushing (front) Oil Pad (braided cotton)....
435C	5861	Arm Shaft (horizontal) Flanged Bushing (front) Set Screw.....
68350	5922	Arm Shaft (horizontal) Front Bearing Oil Cup.....
52060	5898	Arm Shaft (horizontal) Gear with two 1036C.....
52151	5922	Arm Shaft (horizontal) Gear Case (two pieces) with 121E.....
121E	21855	Arm Shaft (horizontal) Gear Case Screw..
1036C	5861	" " " " Set Screw...
144D	5875	" " " " Screw.....
52062	5898	" " (upright).....
56099	5898	" " " Bushing (lower)....
432C	5898	" " " " Set Screw.....
56100	5898	Arm Shaft (upright) Bushing (upper)....
1149C	5875	" " " " " Set Screw.....
56013	5898	Arm Shaft (upright) Gear (lower) with two 1253C.....
1253C	5869	Arm Shaft (upright) Gear (lower) Set Screw.....
56101	5898	Arm Shaft (upright) Gear (upper) with two 1253C.....

No.	Plate	Name
1253C	5869	Arm Shaft (upright) Gear (upper) Set Screw.....
56015	21858	Arm Shaft (upright) Oil Tube (lower)....
56015	21858	" " " " " (upper)....
12193	5870	" Side Cover.....
50053D	21855	" " " Thumb Screw.....
12403	5873	" Spool Pin and Thread Eyelet.....
8879	21856	" " " Washer (cloth).....
52042	21862	" Top Cover.....
52043	-----	" " " 52042 with 12403 and 24131
158D	5889	" " " Screw.....
52005	5850	Balance Wheel (power) light rim, 2 3/16 in. pulley, with two 448C.....
52081	21857	Balance Wheel (stand) heavy rim, 2 11/16 in. pulley, with two 448C.....
52063	5894	Balance Wheel Oil Cover.....
210D	5875	" " " " Screw.....
448C	5872	" " " Set Screw.....
*52064	-----	Bed.....
Note: Due to the accuracy required for gear alignment, Bed cannot be supplied separately and can only be sent out as a unit, Arm and Bed assembled.		
12431	-----	Bed Slide.....
12432	5870	Bed Slide complete, Nos. 4307, 12431 and two 725E.....
4307	5870	Bed Slide Spring.....
725E	5875	" " " Screw.....
52102	-----	Face Plate.....
52103	21857	Face Plate complete, Nos. 52053, 52102, 52170 and two 226J.....
190J	5875	Face Plate Screw.....
52053	21858	" " Thread Guard (lower).....
226J	21855	" " " " " Screw...
52170	21858	" " " " (upper).....
226J	21855	" " " " " Screw...
50190J	21855	" " Thumb Screw.....
52452	5916	Feed Bar.....
313C	5875	" " Screw Center.....
56813	-----	" " " " 313C with 1519J...
1519J	5872	" " " " Nut.....
52165	21858	" Connecting Link.....
375C	5852	" " " " Hinge Screw.....
1518J	5852	" " " " " Nut....
52073	21858	" " " " Stud.....
50083C	21855	" " " " " Set Screw
52126	5857	" Dog, 12 teeth (16 teeth to the inch) for 52128 and 52132.....

Note: No. 52126 is sent with this machine unless another Feed Dog is specified on order.

From the Library of Diamond Blade Corp.

No.	Plate	Name
50117E	5875	Feed Dog Screw.....
24035	5851	" and Feed Lifting Eccentric with 448C.....
448C	5872	Feed and Feed Lifting Eccentric Set Screw.....
24036	5851	Feed and Feed Lifting Eccentric Sleeve..
24037	5851	" Forked Connection.....
375C	5852	" " " Hinge Screw.....
1518J	5852	" " " " " Nut.
52065	5895	" Lifting Rock Shaft.....
52066	-----	Feed Lifting Rock Shaft complete, Nos. 12376 and 52065.....
12430	5851	Feed Lifting Rock Shaft Connecting Rod with two 966E.....
966E	5889	Feed Lifting Rock Shaft Connecting Rod Cap Screw.....
375C	5852	Feed Lifting Rock Shaft Connecting Rod Hinge Screw.....
1518J	5852	Feed Lifting Rock Shaft Connecting Rod Hinge Screw Nut.....
*52271	-----	Feed Lifting Rock Shaft Crank.....
12376	5852	" " " " " 52271 with 157J and 1813.....
157J	5852	Feed Lifting Rock Shaft Crank Clamping Screw.....
1813	5852	Feed Lifting Rock Shaft Crank Roller and Stud.....
50191C	21855	Feed Lifting Rock Shaft Screw Center....
1513J	5872	" " " " " " Nut
52074	21863	" Regulator with 50083C.....
1128E	5852	" " Hinge Screw.....
818D	5852	" " Thumb Screw.....
52068	5895	" Rock Shaft.....
52069	-----	Feed Rock Shaft complete, Nos. 29633 and 52068.....
29633	5852	Feed Rock Shaft Crank with 157J.....
157J	5852	" " " " Clamping Screw....
50191C	21855	" " " " Screw Center.....
1513J	5872	" " " " " Nut.....
5726	21858	Knife.....
Note: Two No. 5726 are sent with this machine.		
620C	21855	Knife Adjusting Screw.....
52104	21863	" Bar with 2301.....
24431	21863	" " Crank with 191C.....
1162C	21855	" " " Coupling Pin.....
1564D	21855	" " " " " Head.....
2297	21856	" " " " " Spring.....
2022	21856	" " " Pin.....
191C	21855	" " " Set Screw.....
24432	-----	Knife Bar Crank complete, Nos. 1162C, 1564D, 2297 and 24431.....

No.	Plate	Name
52105	21863	Knife Bar Driving Crank (forked).....
16564	21863	" " " " Bracket.....
52106	-----	Knife Bar Driving Crank Bracket complete, Nos. 2022, 16564, 24432 and 52105...
647C	21855	Knife Bar Driving Crank Bracket Screw...
24122	21856	" " Lifting Spring.....
24123	21858	" " " " Case.....
*24124	21856	" " " " Guide.....
24906	21856	" " " " " 24124 with 2523 and 24125.....
*24125	21856	Knife Bar Lifting Spring Guide Bracket..
621J	21855	" " " " " " Screw.....
2523	21856	Knife Bar Lifting Spring Guide Pin.....
2301	21856	" " Stop Pin.....
52107	-----	Knife Bar complete, Nos. 621J, 24109, 24906, 52104, 52108 and three 50117E
52108	21862	Knife Holder with 620C, 2291 and two 50117E
24109	21862	" " Handle.....
50117E	5875	" " " Screw.....
50117E	5875	" " " Screw.....
223J	21855	" " " Screw.....
2291	21856	" " Washer.....
52109	21863	Needle Bar (hollow) with 1072F.....
52110	21858	" " Bushing (lower) with 52114.....
1133E	5861	" " " " Set Screw..
52111	21863	" " " (upper).....
1133E	5861	" " " " Set Screw..
*24040	5861	" " Connecting Link with 794E..
24894	-----	" " " " 24040 with 24041.....
794E	5861	Needle Bar Connecting Link Adjusting Screw.....
775E	5861	Needle Bar Connecting Link Cap Screw....
24041	5861	" " " Stud with 207E....
207E	2834	" " " " Clamping Screw
52112	21863	" " Crank (eccentric) with 1036C, 1037C and 1065C.....
52113	21862	Needle Bar Crank (eccentric) Sleeve....
1065C	5875	" " " Position Screw.....
52114	21858	" " " Oil Cup.....
1072F	21855	" " Set Screw.....
12391	5870	Presser Bar (hollow).....
52338	21862	" " Guide Bracket with 223C and 453C.....
453C	5852	Presser Bar Guide Bracket Set Screw....
52016	5852	" " Lifter.....
689C	5852	" " " Hinge Screw.....
1520J	5852	" " " " " Nut.....
12327	5852	" " Lifting and Releasing Lever Bracket.....

From the library of: Diamond Needle Corp.

No.	Plate	Name
11167	5870	Presser Bar Spring.....
11170	5873	" " " Washer.....
24722	5912	" Foot, for 1/32 in. to 11/64 in. gauges for 19103 and 24573.....
19392	5912	Presser Foot, for 3/16 in. gauge and above for 19103 and 24573.....
Note: No. 24722, 1/8 in. gauge, and No.19392, 3/16 in. gauge, are sent with this machine unless other gauges are specified on order.		
190J	5875	Presser Foot Screw.....
50373W	21855	Pressure Regulating Thumb Screw.....
52121	-----	Rotating Hook with three 1253C.....
52123	-----	" " " 52121 with 52090 and four 1053E.....
52089	5898	Rotating Hook 52123 with 40274 and three 1367E (For agents only).....
52298	-----	Rotating Hook 52123 with 40274, 127242 and three 1367E.....
52299	-----	Rotating Hook 52298 with 52237.....
40264	5869	" " " Bobbin.....
52235	-----	" " " Case.....
52236	21861	" " " " 52235 with 591F, 1380E and 40394.....
40392	5869	Rotating Hook Bobbin Case Latch.....
125320	21861	" " " " " Lever...
2974	5869	" " " " " " Fulcrum Pin.....
2975	5869	Rotating Hook Bobbin Case Latch Spring..
592E	5869	" " " " " " Stop Screw.....
40393	-----	Rotating Hook Bobbin Case Hinge, Nos. 2974, 40392 and 125320.....
591F	5869	Rotating Hook Bobbin Case Tension Regulating Screw.....
40394	5869	Rotating Hook Bobbin Case Tension Spring
1380E	5869	" " " " " " " Screw.....
52237	-----	Rotating Hook Bobbin Case complete, Nos. 592E, 2975, 40393 and 52236.....
127241	-----	Rotating Hook Bobbin Case 52237 with 127242.....
127242	21861	Rotating Hook Bobbin Case Holder.....
52018	5869	" " " " " " Position Bracket.....
704J	5869	Rotating Hook Bobbin Case Holder Position Bracket Screw.....
40274	5869	Rotating Hook Section.....
1367E	5869	" " " " Screw.....
1253C	5869	" " " Set Screw.....
52070	5895	" " " Shaft.....

No.	Plate	Name
56106	5898	Rotating Hook Shaft Bushing (back).....
52045	5871	" " " " " " Pack- ing (wick).....
1143C	5917	Rotating Hook Shaft Bushing (back) Set Screw.....
*56107	5898	Rotating Hook Shaft Bushing (front).....
52045	5871	" " " " " " Pack- ing (wick).....
1148C	5871	Rotating Hook Shaft Bushing (front) Set Screw.....
54897	21856	Rotating Hook Shaft Front Bearing Oil Cup.....
56013	5898	Rotating Hook Shaft Gear with two 1253C.
52072	5894	" " " " Case (two pieces) with 121E and 50234E.....
50234E	21855	Rotating Hook Shaft Gear Case Plug Screw
121E	21855	" " " " " " Screw.....
1253C	5869	" " " " " " Set Screw.....
52090	5898	" " " Thread Guard.....
1053E	5869	" " " " " " Screw.....
52115	21863	Slack Thread Regulator.....
223C	21855	" " " " " " Set Screw.....
2102	3471	Tension Disc.....
1560C	5872	" " " " " " Regulating Thumb Nut.....
32572	5872	" " " " " " Releasing Disc.....
43944	5872	" " " " " " Lever.....
12398	5872	" " " " " " Hinge Pin.....
12329	5872	" " " " " " Spring.....
32574	5872	" " " " " " Pin.....
13710	5872	" " " " " " Spring.....
50304C	21855	" " " " " " Stud.....
52098	-----	" " " " " " 50304C with 1560C.....
50305C	21855	" " " " " " Set Screw.....
52092	-----	Tension complete, Nos.13710,32572,32574, 52082, 52083, 52098 and two 2102....
52027	5872	Thread Guard (side of arm).....
52454	5917	" " " Retainer.....
624C	5922	" " " " " " Set Screw.....
52054	-----	Thread Take-up complete, Nos.11204,52025 and 52143.....
52021	5861	Thread Take-up Crank.....
52143	-----	" " " " " " 52021 with 775E and 24894.....
1037C	5861	Thread Take-up Crank Position Screw....
1036C	5861	" " " " " " Set Screw.....
52022	5861	" " " " " " Lever with 52130.....
52023	5861	" " " " " " Hinge Pin.....
52024	5861	" " " " " " Link.....
11204	5861	" " " " " " Hinge Pin.....
435C	5861	" " " " " " " " " Set Screw.....

From the library of: Diamond Needle Co.

No.	Plate	Name
52025	-----	Thread Take-up Lever complete, Nos. 52022 to 52024.....
52130	5917	Thread Take-up Lever Thread Eyelet Bushing.....
52082	21858	Thread Take-up Spring.....
52083	21862	" " " Regulator with 50305C.....
448C	5872	Thread Take-up Spring Regulator Set Screw.....
52127	-----	Throat Plate Body.....
5730	5912	" " Cutting Bar (small needle hole).....
52131	5857	Throat Plate Cutting Bar (large needle hole).....
Note: When ordering Nos. 5730 or 52131, state required distance of trimmed edge from seam.		
Note: No. 5730 3/16 in. gauge is sent with this machine unless another gauge is specified on order.		
578D	5912	Throat Plate Cutting Bar Screw.....
5731	5912	" " Slide.....
578D	5912	" " Adjusting Screw.....
52128	-----	Throat Plate complete (small needle hole) for 52126, Nos. 5730, 5731, 52127 and three 578D.....
52132	5857	Throat Plate complete (large needle hole) for 52126, Nos. 5731, 52127, 52131 and three 578D.....
Note: When ordering Nos. 52128 or 52132, state required distance of trimmed edge from seam.		
Note: No. 52128, 1/8 in. gauge, is sent with this machine unless another Throat Plate is specified on order.		
691F	5875	Throat Plate Screw.....
*15404	-----	Trade Mark.....
15405	-----	" " Rivet.....
24079	5877	Drip Pan.....

ACCESSORIES

No.	Plate	Name
120332	5879	Grease Gun.....
12361	4761	Machine Hinge Connection.....
44139	4761	" " Plate.....
44140	-----	Machine Hinge complete, Nos. 12361, 44139 and merlized wood screw 1-1/4 in. No. 14.....
12405	4761	Machine Rest (felt).....
120342	5879	Oiler (copper plated) with 120343.....
120343	5879	" Spout, 3-1/2 in. long.....
26026	5879	Screw Driver (large).....
26485	5879	" " (small).....
8909	5879	Wrench for 1513 and 1518.....
8908	5879	" " 1519 and 1520.....

BINDER

FOR 95-1 AND 95-10 MACHINES

No.	Plate	Name
35208	1971	Binder on Shank, to turn in both edges for bias or straight binding, for shirts, wrappers, shirt waists, etc.
26603	5905	Feed Dog, 20 teeth (16 teeth to the inch) for 35208.....
52055	5905	Presser Foot for 35208.....
26605	5905	Throat Plate, large needle hole, for 26603.....
26606	-----	Throat Plate, small needle hole, for 26603.....

BOBBIN WINDERS

BOBBIN WINDER

(SWINGING AUTOMATIC, LEFT HAND)

No.	Plate	Name
41913	5902	Bracket with 457C.....
41583	5902	Frame with 457C.....
34105	5902	" Hinge Pin.....
457C	5889	" " " Set Screw.....
41914	5902	" Spring.....
41585	5902	Pulley with 171J.....
171J	5889	" Set Screw.....

BOBBIN WINDER

No.	Plate	Name
41586	5902	Spindle.....
41587	5902	Stop Latch.....
42614	5902	" " Hinge Stud.....
457C	5889	" " " " Set Screw.....
7958	21856	" " Stop Pin.....
41588	5902	" " Tripping Arm with 185J.....
185J	5889	" " " " Clamping Screw..
41591	5902	Tension Bracket with 460C.....
41592	5902	Tension Bracket complete, Nos. 12403, 24131, 41591, 41593 to 41595 and two 2455.....
24131	5873	Tension Bracket Oil Tube with 52045.....
52045	587J	" " " " Packing (wick).
158D	5889	" " Screw.....
12403	5873	" " Spool Pin and Thread Eyelet.....
8879	21856	Tension Bracket Spool Pin Washer (cloth)
2455	2834	" Disc.....
41593	5873	" Spring.....
41594	5873	" Stud.....
460C	5872	" " Set Screw.....
41595	5873	" Thread Guide.....
60845	-----	Bobbin Winder, Nos. 7958, 34105, 41583, 41585 to 41588, 41913, 41914 and 42614
41915	5902	Bobbin Winder 60845 with 880E and 25446.
41916	-----	Bobbin Winder (swinging automatic, left hand) complete, Nos. 41592 and 41915
880E	5889	Bobbin Winder Screw.....
25446	21856	" " " Washer.....

BOBBIN WINDER

(SWINGING AUTOMATIC, RIGHT HAND)

No.	Plate	Name
41339	2833	Base.....
41340	2833	Frame.....
1429D	2834	" Hinge Screw.....
41341	2833	" Spring.....
207D	2834	" " Screw.....
41342	2833	Pulley with 200F.....
200F	2834	" Set Screw.....
41343	2834	Spindle.....
27306	2834	Spool Pin.....
27307	2833	" Stand.....
27308	2833	Spool Stand complete, Nos. 418E, 1562J, 2106, 10141, 11241, 27306, 27307 and two each 2455 and wood screws 1 in. No. 10

BOBBIN WINDER

No.	Plate	Name
11241	2833	Spool Washer (cloth).....
41344	2834	Stop Latch.....
41345	2834	" " Finger.....
152F	2834	" " " Screw.....
1430D	2834	" " Hinge Screw.....
1550J	2834	" " " " Nut.....
41346	2834	" " Lever.....
1430D	2834	" " " Hinge Screw.....
2455	2834	Tension Disc.....
1562J	2834	" Regulating Thumb Nut.....
418E	2834	" Screw Stud.....
10141	2834	" Spring.....
2106	2834	" Thread Guide.....
60456	-----	Bobbin Winder, Nos. 152F, 207D, 1429D, 1550J, 41339 to 41346 and three 1430D.....
41347	2833	Bobbin Winder, No. 60456 and two each 9331 and wood screws 1 in. No. 10...
41348	-----	Bobbin Winder (swinging automatic, right hand) complete, Nos. 27308 and 41347
9331	2834	Bobbin Winder Washer.....

BOBBIN WINDER

(SWINGING AUTOMATIC, RIGHT HAND)

FOR POWER TABLE

No.	Plate	Name
225433	-----	Bobbin Winder and Tension Bracket Base..
225453	3470	Frame with 202277 and 225438.....
225454	3471	" Hinge Pin.....
202277	3471	" Oil Packing (wick).....
225438	3471	" " Well Cap.....
225455	3471	" Spring.....
225456	3471	" " Plunger.....
202473	3470	Pulley with 200380C.....
200380C	3471	" Set Screw.....
225381	3470	Spindle.....
225444	3471	Stop Latch.....
200056E	3471	" " Screw.....
225458	3471	" " Thumb Lever.....
225459	3471	" " " " Hinge Stud.....
225459	3471	" " " " Joint Stud.....
202478	3471	" " Trip Lever.....
200299H	3471	" " " " Hinge Screw.....
225461	3471	Tension Bracket with 201499B.....
200082D	3471	" " Screw.....

From the library of: Diamond Net 80

No.	Plate	Name
228026	-----	Tension Bracket Screw Washer.....
2102	3471	" Disc.....
202407	3471	" Spring.....
201499B	3471	" Stud.....
201572B	3471	" Thumb Nut.....
225462	-----	Tension Bracket complete, Nos. 201572B, 202407, 225461 and two 2102.....
225382	-----	Bobbin Winder complete, Nos. 200056E, 200082D, 200299H, 202473, 202478, 225381, 225433, 225444, 225453 to 225456, 225458, 225462, 228026, two each 225459 and wood screws 3/4 in. No. 12 R.H.....

FINGER GUARDS

FOR 95-1, 95-2, 95-10 AND 95-11 MACHINES

No.	Plate	Name
36818	5945	Finger Guard.....
36819	5945	" " Friction Washer.....
50316J	5945	" " Hinge Screw.....
36820	5945	" " Holder with 196J.....
196J	5945	" " Clamping Screw.....
36821	5945	Finger Guard complete, Nos. 36818 to 36820 and 50316J.....
120856	5892	Finger Guard.....
120358	5892	" " Holder with 50302J.....
50302J	5892	" " Screw.....
120859	5892	Finger Guard complete, Nos. 120856, 120858 and two 236J.....
236J	5892	Finger Guard Screw.....

FOOT LIFTER PARTS

FOR 95-1, 95-2, 95-10 AND 95-11 MACHINES

No.	Plate	Name
5596	5878	Bell Crank.....
56848	-----	" " 5596 with 5599 and 5601.....
5599	5878	" " Bracket.....
178E	5875	" " Screw.....
5601	4761	" " Hinge Pin.....
5735	4761	" " Spring.....

No.	Plate	Name
5598	5878	Bell Crank complete, Nos. 5735 and 56848
5670	-----	Chain, length 26 in. to 35 in. with 56864 and 56865.....
Note: When ordering No. 5670, give length required		
4879	5878	Chain Connecting Link.....
56864	5917	" Hook (large).....
56865	5917	" " (small).....
16510	5878	Lifting Lever with 448C.....
52028	5878	" " Connecting Rod.....
12416	4761	" " " " Joint.....
76D	4761	" " " " Hinge Screw.....
1521E	4761	Lifting Lever Connecting Rod Lock Nut...
802D	5875	" " Hinge Screw.....
12241	21856	" " Link.....
766D	5875	" " Hinge Screw.....
12240	21856	" " Pin.....
448C	5872	" " Set Screw.....
2763	5876	Rock Shaft.....
12242	5876	" " Hanger with two wood screws 1 in. No. 10.....
6337	5876	Rock Shaft Lifting Bracket with two 356C
12243	5876	" " " " Hook.....
7125	5876	" " " " Hook.....
356C	5875	" " " " Set Screw
356C	5875	" " " " Set Screw
2770	5876	" " Stop Dog with 356C.....
356C	5875	" " " " Set Screw.....
4880	5876	Rock Shaft complete, Nos. 2763, 2770, 7125, 12243 and two each 6337 and 12242...
4881	5876	Treadle.....
4882	5878	" Shaft.....
4883	5878	" Spring.....
4884	5876	" Stand.....
4885	5876	Treadle complete, Nos. 4879, 4881 to 4884 and two wood screws 1 in. No. 16....
52029	-----	Foot Lifter complete, Nos. 76D, 766D, 802D, 1521E, 4880, 4885, 5598, 5670, 12240, 12241, 12416, 16510, 52028 and two 178E

FOOT LIFTER PARTS

FOR 95-12 MACHINE

No.	Plate	Name
5596	5878	Bell Crank.....
56848	-----	" " 5596 with 5599 and 5601.....

FOOT LIFTER PARTS

No.	Plate	Name
5599	5878	Bell Crank Bracket.....
178E	5875	" " " Screw.....
5601	4761	" " Hinge Pin.....
5735	4761	" " Spring.....
5598	5878	Bell Crank complete, Nos. 5735 and 56848
5670	-----	Chain, length 26 in. to 35 in., with 56864 and 56865.....
Note: When ordering No. 5670, give length required		
4879	5878	Chain Connecting Link.....
56864	5917	" Hook (large).....
56865	5917	" " (small).....
16585	21857	Lifting Lever with 448C.....
52028	5878	" " Connecting Rod.....
12416	4761	" " " " Joint.....
76D	4761	" " " " " Hinge Screw.....
1521E	4761	Lifting Lever Connecting Rod Lock Nut...
802D	5875	" " Hinge Screw.....
12241	21856	" " Link.....
766D	5875	" " Hinge Screw.....
16586	21862	" " Pin.....
448C	5872	" " Set Screw.....
2763	5876	Rock Shaft.....
12242	5876	" " Hanger with two wood screws 1 in. No. 10.....
6337	5876	Rock Shaft Lifting Bracket with two 356C
12243	5876	" " " " Hook.....
7125	5876	" " " " Hook.....
356C	5875	" " " " Set Screw
356C	5875	" " " " Set Screw....
2770	5875	" " Stop Dog with 356C.....
356C	5875	" " " " Set Screw.....
4880	5876	Rock Shaft complete, Nos. 2763, 2770, 7125, 12243 and two each 6337 and 12242...
4881	5876	Treadle.....
4882	5878	" Shaft.....
4883	5878	" Spring.....
4884	5876	" Stand.....
4885	5876	Treadle complete, Nos. 4879, 4881 to 4884 and two wood screws 1 in. No. 16....
52116	-----	Foot Lifter complete, Nos. 76D, 766D, 802D, 1521E, 4880, 4885, 5598, 5670, 12241, 12416, 16585, 16586, 52028 and two 178E

HEMMERS

FOR 95-1 AND 95-10 MACHINES

No.	Plate	Name
120938	5921	Hemmer (foot) for 3/32 in. hem.....

HEMMERS

No.	Plate	Name
120803	5919	Hemmer (foot) for 1/8 in. hem.....
120804	5919	" " " 5/32 in. hem.....
120805	5919	" " " 3/16 in. hem.....
36122	-----	" " " 7/32 in. hem.....
120806	5920	" " " 1/4 in. hem.....
120807	5920	" " " 5/16 in. hem.....
6267	5873	" Folder for 36122.....
120939	5919	" " " 120803 to 120807 and 120938.....
25888	5873	Hemmer Tongue for 36122.....
*120838	5919	" " " 120804 and 120805....
*120839	5920	" " " 120806 and 120807....
*120843	5919	" " " 120803 and 120938....
Note: When ordering Hemmer Folders or Hemmer Tongues, state width of hem and No. of hemmer for which it is required.		
20117	5853	Feed Dog, for shirt work, beveled for hemmer, 16 teeth (16 teeth to the inch) for 36122, 120803 to 120807 and 120938.....
20132	5853	Feed Dog, for shirt work, beveled for hemmer, 22 teeth (22 teeth to the inch) for 36122, 120803 to 120807 and 120938.....
20124	5853	Throat Plate, large needle hole, for 20117 and 20132.....
20125	-----	Throat Plate, small needle hole, for 20117 and 20132.....
35710	-----	Hemmer (foot) 3/32 in. hem, with guide on bottom to the right of needle hole.....
35682	21860	Hemmer (foot) 1/8 in. hem, with guide on bottom to the right of needle hole..
36524	-----	Hemmer (foot) 5/32 in. hem, with guide on bottom to the right of needle hole..
35997	-----	Hemmer (foot) 3/16 in. hem, with guide on bottom to the right of needle hole.....
36309	-----	Hemmer (foot) 7/32 in. hem, with guide on bottom to the right of needle hole.....
36072	-----	Hemmer (foot) 1/4 in. hem, with guide on bottom to the right of needle hole..
36525	21859	Feed Dog, 20 teeth (18 teeth to the inch) for 35682, 35710, 35997, 36072, 36309 and 36524.....
36526	21859	Throat Plate for 36525.....
36162	-----	Hemmer (foot) 3/32 in. hem, for China silk, etc.....
120898	5921	Hemmer (foot) 1/16 in. to 1/8 in. hem, for China silk, etc.....

No.	Plate	Name
120911	5921	Hemmer (foot) 5/32 in. to 1/4 in. hem, for China silk, etc.....
36434	-----	Hemmer (foot) 3/16 in. hem, for China silk, etc.....
52031	5856	Feed Dog, for shirt work, 19 teeth (22 teeth to the inch) for 36162, 36434, 52032, 52033, 120898 and 120911.....
52032	-----	Throat Plate, large needle hole, for 52031.....
52033	5856	Throat Plate, small needle hole, for 52031.....
36413	-----	Hemmer (foot) plain bottom, 1/16 in. hem
36414	-----	" " " " 3/32 in. hem
36480	-----	" " " " 5/32 in. hem
36416	-----	" " " " 3/16 in. hem
120837	5920	" " " " 1/8 in. hem slotted for lace.....

HEMMERS ON SHANK

FOR 95-I AND 95-10 MACHINES

No.	Plate	Name
35926	-----	Hemmer.....
590J	5889	" Adjusting Screw.....
1443B	5889	" Screw.....
35927	-----	" Shank.....
35540	21861	Hemmer on Shank complete with right hand lower guide for lace, Nos. 1443B, 35926, 35927 and two 590J.....
20163	5857	Feed Dog, 1/6 in. stitch, 16 teeth (16 teeth to the inch) for 35540.....
62527	21861	Presser Foot Hinge Pin.....
40316	-----	" " Plate.....
40317	-----	" " Shank.....
40318	2186C	Presser Foot (hinged) complete, for lace running, for 20163, Nos. 40316, 40317 and 62527.....
20123	5857	Throat Plate for 20163.....
35236	1971	Hemmer on Shank, for 7/16 in. hem.....
26603	5905	Feed Dog, 20 teeth (16 teeth to the inch) for 35236.....
52055	5905	Presser Foot for 35236.....
26605	5905	Throat Plate, large needle hole, for 26603.....
26606	-----	Throat Plate, small needle hole, for 26603.....

KNEE LIFTER PARTS

FOR 95-I, 95-2, 95-10 AND 95-II MACHINES

No.	Plate	Name
5596	5878	Bell Crank.....
56848	-----	" " 5596 with 5599 and 5601.....
5599	5878	" " Bracket.....
178E	5875	" " " Screw.....
5601	4761	" " Hinge Pin.....
5735	4761	" " Spring.....
5598	5878	Bell Crank complete, Nos. 5735 and 56848
16510	5878	Lifting Lever with 448C.....
52028	5878	" " Connecting Rod.....
12416	4761	" " " " Joint.....
76D	4761	" " " " Hinge Screw.....
1521E	4761	Lifting Lever Connecting Rod Lock Nut.....
802D	5875	" " Hinge Screw.....
12241	21856	" " Link.....
766D	5875	" " " Hinge Screw.....
12240	21856	" " Pin.....
448C	5872	" " Set Screw.....
2759	5877	" Rod with 2761.....
2761	5872	" " Cap (washer).....
2762	21858	" " Collar with 362C.....
362C	21855	" " " Set Screw.....
2760	-----	Lifting Rod complete, Nos. 2759 and 2762
2763	5876	Rock Shaft.....
12242	5876	" " Hanger with two wood screws 1 in. No. 10.....
2765	5877	Rock Shaft Knee Arm for 2768.....
6335	5877	" " " " 6336.....
2766	5877	" " " " Hub with 356C.....
356C	5875	" " " " Set Screw.....
2768	-----	Rock Shaft Knee Arm complete for 2777, Nos. 2765 to 2767.....
6336	-----	Rock Shaft Knee Arm complete for 19168, Nos. 2766, 2767 and 6335.....
2767	5877	Rock Shaft Knee Plate with 356C.....
356C	5875	" " " " Set Screw.....
2769	5877	" " Lifting Arm with 356C.....
356C	5875	" " " " Set Screw.....
6337	5876	" " " " Bracket with two 356C
2778	5877	" " " " Hook.....
356C	5875	" " " " " Set Screw
356C	5875	" " " " " Set Screw....
2770	5876	" " Stop Dog with 356C.....

KNEE LIFTER PARTS

No.	Plate	Name
356C	5875	Rock Shaft Stop Dog Set Screw.....
2777	5877	Rock Shaft complete for 52030, Nos.2763, 2768, 2770, 2778, 6337 and two 12242
19168	-----	Rock Shaft complete for 52038, Nos.2760, 2763, 2769, 6336 and two each 2770 and 12242.....
52030	-----	Knee Lifter complete (power table) Nos. 76D,766D,802D,1521E,2777,5598,12240, 12241,12416,16510,52028 and two 178E
52038	-----	Knee Lifter complete (bench stand) Nos. 76D,766D,802D,1521E,5598,12240,12241, 12416,16510,19168,52028 and two 178E

KNEE LIFTER PARTS

FOR 95-12 MACHINE

No.	Plate	Name
5598	5878	Bell Crank.....
56848	-----	" " 5598 with 5599 and 5601.....
5599	5878	" " Bracket.....
178E	5875	" " " Screw.....
5601	4761	" " Hinge Pin.....
5735	4761	" " Spring.....
5598	5878	Bell Crank complete, Nos. 5735 and 56848
16585	21857	Lifting Lever with 448C.....
52028	5878	" " Connecting Rod.....
12416	4761	" " " " Joint.....
76D	4761	" " " " " Hinge Screw.....
1521E	4761	Lifting Lever Connecting Rod Lock Nut...
802D	5875	" " Hinge Screw.....
12241	21856	" " Link.....
766D	5875	" " " Hinge Screw.....
16586	21862	" " Pin.....
448C	5872	" " " Set Screw.....
2763	5876	Rock Shaft.....
12242	5876	" " Hanger with two wood screws 1 in. No. 10.....
2765	5877	Rock Shaft Knee Arm.....
2766	5877	" " " " Hub with 356C.....
356C	5875	" " " " " Set Screw.....
2768	-----	Rock Shaft Knee Arm complete for 2777, Nos. 2765 to 2767.....
2767	5877	Rock Shaft Knee Plate with 356C.....
356C	5875	" " " " " Set Screw.....
6337	5876	" " " Lifting Bracket with two 356C

KNEE LIFTER PARTS

No.	Plate	Name
2778	5877	Rock Shaft Lifting Bracket Hook.....
356C	5875	" " " " " Set Screw
356C	5875	" " " " " Set Screw....
2770	5876	" " Stop Dog with 356C.....
356C	5875	" " " " " Set Screw.....
2777	5877	Rock Shaft complete, Nos.2763,2768,2770, 2778, 6337 and two 12242.....
52117	-----	Knee Lifter complete (power table) Nos. 76D,766D,802D,1521E,2777,5598,12241, 12416,16595,16586,52028 and two 178E

KNIFE GRINDER

FOR 95-12 MACHINE

No.	Plate	Name
27565	1104	Emery Wheel, 2 in. diam.....
1508J	1105	" " Clamping Nut.....
27822	1105	" " " " Washer.....
27567	1105	" " Shaft.....
60934	-----	" " " 27567 with 1508J, 27565, 27569 and 27822.....
27568	1105	Emery Wheel Shaft Oil Hole Cover (rubber)
27569	1105	" " " Pulley.....
310K	1105	" " " " Screw Center.....
1516J	1105	" " " " " Nut.....
27564	1104	Frame with 27574.....
899J	1105	Knife Clamping Screw.....
126392	5916	" Holder for 126393.....
27657	-----	" " Body for 27658.....
27679	-----	" " " " 27681.....
27658	1105	Knife Holder complete for 27661, Nos. 899J, 27657 and 27660.....
27681	21862	Knife Holder complete, Nos.899J, 11833, 27660 and 27679.....
126393	-----	Knife Holder complete, Nos. 227J, 899J, 27660, 126392 and 126394.....
27323	1105	Knife Holder Guide Bar.....
27572	1104	" " " " Bracket with 27574
310K	1105	" " " " " Screw Center ter.....
1516J	1105	Knife Holder Guide Bar Bracket Screw Center Nut.....
27573	1105	Knife Holder Guide Bar Bracket Spring...
27574	1105	" " " " " " "
		Hook.....
27659	1105	Knife Holder Stop Collar with 237K.....

No.	Plate	Name
237K	1105	Knife Holder Stop Collar Set Screw.....
27660	21856	" Position Pin for 27658.....
27660	21856	" " " (lower) for 27681 and 126393.....
11833	21856	Knife Position Pin (upper) for 27681....
261J	1105	" Regulating Thumb Screw.....
126394	5917	" Stop.....
227J	5917	" " Screw.....
27662	1104	Wrench for 1508 and 1516.....
*60583	5918	Knife Grinder, Nos. 261J, 27323, 27564, 27572, 27573, 27659, 60934, two 27568 and four each 310K and 1516J.....
27661	-----	Knife Grinder complete, Nos. 27662, 60583, either 27659, 27681 or 126393 and three wood screws 1 in. No. 10.....

MACHINE BASE

No.	Plate	Name
24106	4761	Bed Frame Cushion (felt).....
158E	5889	" " " Screw.....
24107	4761	" " Hinge Connection.....
9261	4761	" " " " Pin.....
970D	4761	" " Thumb Screw.....
24108	5876	Bed Frame complete, Nos. 970D, two each 9261, 24107, four each 158E, 24106 and six wood screws 1 1/4 in. No. 12....

PIPING ATTACHMENT

FOR 95-I AND 95-10 MACHINES

No.	Plate	Name
35245	21861	Piping Attachment for piping housedresses
44253	5856	Feed Dog, for cloth, 16 teeth (16 teeth to the inch) for 44255 and 44256....
52056	21860	Presser Foot for 35245.....
44256	5856	Throat Plate, large needle hole, for 44253.....
44255	-----	Throat Plate, small needle hole, for 44253.....

PRESSER FEET

No.	Plate	Name
36464	5892	Presser Foot Spring Guide.....
665J	5892	" " " " Screw.....
36465	5892	" " (right hand spring guide) with 665J and 36464, for 1/32 in. to 5/16 in. gauges.....
Note: When ordering No. 36464 or 36465, state re- quired distance from edge of goods to seam.		
36574	5945	Presser Foot.....
36575	5945	" " 36574 with 36576 and two 50202J.....
36576	5945	Presser Foot Finger Guard.....
50202J	5945	" " " " Screw.....
36714	-----	" " with 233J.....
36715	5892	" " Guide (right) with 36716..
233J	5892	" " Set Screw.....
36716	5892	" " Stud.....
36717	5892	Presser Foot complete with Adjustable Guide (right) Nos. 36714 and 36715..
36773	5892	Presser Foot, for braiding.....
120828	5922	" " (single toe) for gathering, for fine work.....

PRESSER FOOT EXTENSIONS

FOR 95-2 AND 95-11 MACHINES

No.	Plate	Name
26279	5089	Presser Foot Extension, 1/16 in.....
26280	5089	" " " 1/8 in.....
26281	5089	" " " 1/4 in.....
26282	5089	" " " 3/8 in.....
26283	5089	" " " 1/2 in.....
228J	5875	" " " Screw.....
25967	5089	" " Strip Gauge.....
228J	5875	" " " " Screw.....

SPOOL HOLDER (Disc)

FOR 95-2 AND 95-11 MACHINES

No.	Plate	Name
26763	5879	Bracket with 219F and 51224D

No.	Plate	Name
219F	5875	Bracket Screw.....
51224D	21855	" Thumb Screw.....
19066	5879	Spindle.....
19067	5879	Thread Guiding Disc.....
691F	5875	" " " Screw.....
26764	5879	Spool Holder (disc) complete, Nos. 691F, 19066, 19067 and 26763.....

THREAD UNWINDER

FOR TWO SPOOLS

No.	Plate	Name
225257	20335	Spool Rest with 201018C.....
150203	20335	" " Cushion (felt).....
225388	20335	" " Rod.....
200383C	5917	" " " Set Screw.....
201018C	5917	" " Set Screw.....
202490	20335	" Stand with 200383C.....
225391	20335	Thread Guide.....
201696J	5917	" " Lock Nut.....
225326	5922	" " Position Cup.....
225324	20335	" " Rod with 208E and 225322....
208E	5889	" " " Screw.....
225322	5922	" " " Washer.....
225258	20335	Thread Unwinder complete, Nos. 201696J, 202490, 225257, 225324, 225326, 225388, two each 150203, 225391 and three wood screws 7/8 in. No. 12.....
27739	7234	Thread Cone (wood) for large cones.....
225390	7234	" " Holder, for inverted cones..

Note: Nos. 27739 and 225390 are used with, but not included in 225258.

TUCKERS (Long Arm)

FOR 95-1, 95-2, 95-10 AND 95-11 MACHINES

No.	Plate	Name
36387	5884	Space Guide.....
35510	5884	" " Base with 35512, 35514 and two 1426E.....
402D	5885	Space Guide Base Screw.....
35511	5885	" " Indicator.....

No.	Plate	Name
35512	5885	Space Guide Pin.....
35513	5885	" " Stop (left).....
35514	5885	" " " " Guide Pin.....
1426E	5885	" " " " Screw Stud.....
1657D	5885	" " " " Thumb Nut.....
17718	5885	" " " " " Washer
35515	5885	Space Guide Stop (right).....
1426E	5885	" " " " Screw Stud.....
1657D	5885	" " " " Thumb Nut.....
17718	5885	" " " " " Washer
51224D	21855	" " Thumb Screw.....
36388	-----	Space Guide complete, Nos. 51224D, 35510, 35511, 35513, 35515, 36387 and two each 1657D and 17718.....
35517	5883	Tuck Guide Arm.....
1177D	5885	" " " Screw.....
35518	5883	" " Base.....
50134E	5885	" " " Screw Stud.....
36389	5883	" " Bracket.....
307C	5875	" " " Screw Center.....
56814	-----	" " " " 307C with 1513J.....
1513J	5872	Tuck Guide Bracket Screw Center Nut....
36390	5885	" " " Spring.....
36391	5884	" " " Plate.....
9D	5885	" " " Screw.....
423C	5885	" " " Stop Screw.....
1520J	5852	" " " " Nut.....
36392	5883	" " Frame.....
36393	5885	" " " Spring.....
1510J	5885	" " " Nut.....
35524	5885	" " " Washer.....
803C	5885	" " " Stop Screw.....
1520J	5852	" " " " Nut.....
35511	5885	" " Indicator.....
35525	5883	" " Plate.....
1115F	5885	" " Screw.....
36394	-----	Tuck Guide complete, Nos. 9D, 423C, 803C, 1510J, 35511, 35517, 35518, 35524, 35525, 36389 to 36393, 50134E, two each 1115F, 1177D, 1520J, 56814 and three wood screws 1 1/4 in. No. 10.....
36395	-----	Tucker (long arm) complete, Nos. 35528, 36388, 36394 and two 402D.....
52031	5856	Feed Dog, for shirt work, 19 teeth (22 teeth to the inch).....
35528	5886	Presser Foot (wide) for 36395.....
40322	5886	" " (narrow) for 36395.....
36654	5886	" " for tucking shirt bosoms, for 36670.....

From the library of Diamond Needle Corp.

No.	Plate	Name
52032	-----	Throat Plate, large needle hole, for 52031.....
52033	5856	Throat Plate, small needle hole, for 52031.....
36670	-----	Tucker (long arm) complete, for tango tucking, Nos.36388, 36394, 36654 and two 402D.....

OBSOLETE PARTS

No.	Plate	Name
*52001	-----	Arm with 11104, for 95-1 Machine.....
52120	21858	" Oil Tube with 52045, for oiling 24040, for 95-12 Machine, use 52084..
29599	5873	Arm Oil Tube Packing (felt), use 52045..
*11104	-----	" Shaft Bushing (front) for 52001.....
56006	21856	" " Flanged Bushing (back) Oil Pad (braided cotton) for 95-1 and 95-2 Machines, use 52146.....
56006	21856	Arm Shaft Flanged Bushing (front) Oil Pad (braided cotton) for 95-1 and 95-2 Machines, use 52146.....
54897	21856	Arm Shaft Front Bearing Oil Cup for 95-10 to 95-12 Machines, use 68350..
52058	5895	Arm Shaft (horizontal) for 95-10 and 95-11 Machines, obsolete, superseded by 52141, not interchangeable.....
56006	21856	Arm Shaft (horizontal) Flanged Bushing (back) Oil Pad (braided cotton) for 95-10 to 95-12 Machines, use 52146..
56006	21856	Arm Shaft (horizontal) Flanged Bushing (front) Oil Pad (braided cotton) for 95-10 to 95-12 Machines, use 52146..
52071	5894	Arm Shaft (horizontal) Gear Case (two pieces) with 121E and 50234E, for 95-10 to 95-12 Machines, obsolete, superseded by 52151, not interchangeable.....
50234E	21855	Arm Shaft (horizontal) Gear Case Plug Screw for 52071
286D	5875	Arm Side Cover Thumb Screw, use 50053D..
22546C	3471	Bobbin Winder Stop Latch Thumb Lever Joint Stud.....
52007	-----	Face Plate for 52008.....
52008	5850	Face Plate complete for 95-1 Machine, Nos.52007,52009 and 52010, use 52052
52009	5873	Face Plate Thread Guard (lower) for 52008.....

No.	Plate	Name
52010	5873	Face Plate Thread Guard (upper) for 52008.....
56086	-----	Face Plate Thread Guard (upper), use 52170.....
52011	5851	Feed Bar, use 52452.....
12369	5855	" Dog, for cloth, 12 teeth (12 teeth to the inch) for 20190 and 20191....
12457	5855	Feed Dog, for cloth, 16 teeth (16 teeth to the inch) for 20190 and 20191....
19103	5912	Feed Dog, 12 teeth (16 teeth to the inch) for 5732.....
24573	5912	Feed Dog, 24 teeth (32 teeth to the inch) for 5732.....
24035	5851	Feed and Feed Lifting Eccentric with 448C, for 95-10 and 95-11 Machines, use 52137.....
3033	5852	Feed Connecting Link, use 52165.....
145E	5875	" Lifting Rock Shaft Crank Connecting Rod Cap Screw, use 966E.....
2049	5852	Feed Lifting Rock Shaft Crank (back) Pin for 95-1 and 95-2 Machines, use 3093.
732D	5875	Guide Thumb Screw for 95-1 and 95-10 Machines, use 50190W.....
36118	-----	Hemmer (foot) 3/32 in. hem, for 95-1 and 95-10 Machines.....
36119	21860	Hemmer (foot) 1/8 in. hem, for 95-1 and 95-10 Machines.....
36120	-----	Hemmer (foot) 5/32 in. hem, for 95-1 and 95-10 Machines.....
36121	-----	Hemmer (foot) 3/16 in. hem, for 95-1 and 95-10 Machines.....
36749	-----	Hemmer (foot) 1/4 in. hem, for 95-1 and 95-10 Machines.....
52012	5861	Needle Bar (hollow) with 957C, for 95-1, 95-2, 95-10, and 95-11 Machines, use 52129.....
858C	5875	Needle Bar Crank Set Screw.....
2532	5873	Presser Foot Hinge Pin.....
52124	-----	Rotating Hook 52089 with 52442, use 52478
127060	-----	" " 52123 with 40274, 127100 and three 1367E, use 52298.....
52478	-----	Rotating Hook 127060 with 52237, use 52299.....
52076	5869	Rotating Hook with 40274, 40398, two 1253C and three each 1053E and 1367E for 95-10 Machine, use 52089.....
40261	5871	Rotating Hook Belt Pulley (lower, steel) with 1147C, 50143C and sixteen 40263, for 52017.....

From the Library of: Department of...

OBSOLETE PARTS

No.	Plate	Name
52040	5887	Rotating Hook Belt Pulley (lower, steel) with two 1147C, and sixteen 40263, for 52041.....
1147C	5889	Rotating Hook Belt Pulley (lower) Position Screw for 40261 and 52040.....
50143C	5871	Rotating Hook Belt Pulley (lower) Set Screw for 40261.....
40263	5871	Rotating Hook Belt Pulley (lower) Stud for 40261 and 52040.....
52017	5871	Rotating Hook Belt Pulley (upper) with 1362C and thirty 40263, for 40261, for 95-1 and 95-2 Machines.....
52041	5887	Rotating Hook Belt Pulley (upper) with 1362C and thirty 40263, for 52040...
40431	-----	Rotating Hook Bobbin Case for 40395, use 52472.....
40395	5869	Rotating Hook Bobbin Case complete for 40408 and 52442, Nos.591F,592E,1380E, 2975, 40393, 40394 and 40431, use 52473.....
40408	-----	Rotating Hook Bobbin Case 40395 with 40396, use 52442.....
52442	-----	Rotating Hook Bobbin Case 40395 with 52443, for 52124, use 52474.....
52472	-----	Rotating Hook Bobbin Case, use 52235....
52481	-----	" " " " 52472 with 591F, 1380E and 40394, use 52236....
52474	-----	Rotating Hook Bobbin Case 52473 with 52477, use 127099.....
127099	-----	Rotating Hook Bobbin Case 52237 with 127100, use 127241.....
52477	5917	Rotating Hook Bobbin Case Holder with 52475 and 52476, use 127100.....
127100	-----	Rotating Hook Bobbin Case Holder, use 127242.....
52473	5917	Rotating Hook Bobbin Case complete, Nos. 592E, 2975, 40393 and 52481, use 52237.....
40409	5869	Rotating Hook Bobbin Case Latch Lever, use 125320.....
40396	5869	Rotating Hook Bobbin Case Holder for 40408, use 52443.....
52443	21861	Rotating Hook Bobbin Case Holder for 52442.....
52475	5917	Rotating Hook Bobbin Case Locating Plate for 52477.....
52476	5917	Rotating Hook Bobbin Case Locating Plate Rivet for 52477.....
40276	5871	Rotating Hook Shaft Bushing (back) for 95-1 and 95-2 Machines, use 52044...

OBSOLETE PARTS

No.	Plate	Name
52020	5871	Rotating Hook Shaft Bushing (front) for 95-1 and 95-2 Machines, use 52039...
1148C	5871	Rotating Hook Shaft Bushing (front) Set Screw for 95-1 and 95-2 Machines....
40398	5869	Rotating Hook Thread Guard for 52076....
20060	5872	Slack Thread Regulator for 95-10 and 95-11 Machines, use 52337.....
225F	5872	Slack Thread Regulator Set Screw for 95-10 and 95-11 Machines, use 223C..
287D	5875	Spool Holder Bracket Thumb Screw, use 51224D.....
1274C	5872	Tension Screw Stud for 95-1, 95-2, 95-10 and 95-11 Machines.....
2103	21856	Tension Spring for 95-10 and 95-11 Machines.....
29642	5872	Thread Eyelet (side of arm) for 95-10 Machine, use 52171.....
52026	5861	Thread Eyelet for 95-1, 95-2, 95-10 and 95-11 Machines, use 52171.....
210958	21856	Thread Retaining Collar for 52379.....
210993	21856	" " Sleeve for 52379.....
52398	21858	" " Spring for 52379.....
52378	21858	" " Stud for 52379.....
52379	-----	Thread Retainer complete for 95-10 to 95-12 Machines, Nos. 52378, 52398, 210958 and 210993.....
460C	5872	Thread Retainer Set Screw for 95-10 to 95-12 Machines.....
43946	5872	Thread Take-up Spring.....
52348	-----	" " Spring.....
7336	5872	" " " Regulator.....
225395	7233	" Unwinder Spool Rest with 201018C for 225396.....
225392	-----	Thread Unwinder Thread Guide Rod with 208E and 225393, for 225396....
225393	5917	Thread Unwinder Thread Guide Rod Washer for 225392.....
225396	7233	Thread Unwinder complete, Nos. 201696J, 20249C, 225324, 225326, 225388, 225395, two 225391 and three wood screws 7/8 in. No. 12, use 225258.....
5729	-----	Throat Plate Body for 5732.....
5732	5912	Throat Plate complete, for 19103 and 24573, Nos.5729 to 5731 and two 578D
12411	21859	Throat Plate (large needle hole) for 12457.....
20190	5855	Throat Plate (large needle hole) for 12369 and 12457.....
20191	-----	Throat Plate (small needle hole) for 12369 and 12457.....
236F	5892	Throat Plate Slide Adjusting Screw for 5732.....
287D	5875	Tucker Space Guide Thumb Screw, use 51224D

Firm the library of David Neede

NUMERICAL LIST OF PARTS

No.	Plate	Name
9D	5885	Tucker Tuck Guide Bracket Spring Screw for 36394.....
76D	4761	Lifting Lever Connecting Rod Joint Hinge Screw for 52029, 52030, 52038, 52116 and 52117.....
116E	5875	Arm Screw (back).....
121E	21855	" Shaft (horizontal) Gear Case Screw for 52071 and 52151.....
121E	21855	Rotating Hook Shaft Gear Case Screw for 52072.....
144D	5875	Arm Shaft (horizontal) Screw for 95-10 to 95-12 Machines.....
144D	5875	Arm Shaft Screw for 95-1 and 95-2 Machines.....
145E	5875	Feed Lifting Rock Shaft Crank Connecting Rod Cap Screw, obsolete, use 966E..
152F	2834	Bobbin Winder Stop Latch Finger Screw for 60456.....
157J	5852	Feed Lifting Rock Shaft Crank Clamping Screw for 12376.....
157J	5852	Feed Lifting Rock Shaft Crank (front) Clamping Screw for 12376.....
157J	5852	Feed Rock Shaft Crank Clamping Screw for 29633.....
158D	5889	Arm Top Cover Screw for 95-10 to 95-12 Machines.....
158E	5889	Bed Frame Cushion Screw for 24108.....
158D	5889	Bobbin Winder Tension Bracket Screw.....
171J	5889	" " Pulley Set Screw for 41585
178E	5875	Bell Crank Bracket Screw for 52029, 52030, 52038, 52116 and 52117.....
181D	5875	Rotating Hook Belt Guard Screw for 95-1 and 95-2 Machines.....
185J	5889	Bobbin Winder Stop Latch Tripping Arm Clamping Screw for 41588.....
190J	5875	Face Plate Screw.....
190J	5875	Presser Foot Screw.....
191C	21855	Knife Bar Crank Set Screw for 24431.....
196J	5945	Finger Guard Holder Clamping Screw for 36820.....
200F	2834	Bobbin Winder Pulley Set Screw for 41342
207D	2834	" " Frame Spring Screw for 60456.....
207E	2834	Needle Bar Connecting Stud Clamping Screw for 24041.....
208E	5889	Thread Unwinder Thread Guide Rod Screw for 225324 and 225392.....

SINGER Needles should be used
 in **SINGER** Machines
 These Needles and their Containers
 are marked with the
 Company's Trade Mark "**SIMANCO**."** 1

Needles in Containers marked
 "**FOR SINGER MACHINES**"
 are **NOT SINGER** made needles. 2

No.	Plate	Name
210D	5875	Balance Wheel Oil Cover Screw.....
219J	5875	Arm Side Cap Screw for 95-1, 95-2, 95-10 and 95-11 Machines.....
219F	5875	Spool Holder Bracket Screw for 26763....
223J	21855	Knife Screw for 52108.....
223C	21855	Slack Thread Regulator Set Screw for 52338.....
225F	5872	Slack Thread Regulator Adjusting Screw for 95-1 and 95-2 Machines.....
225F	5872	Slack Thread Regulator Set Screw for 95-10 and 95-11 Machines, obsolete, use 223C.....
226J	21855	Face Plate Thread Guard (lower) Screw for 52052 and 52103.....
226J	21855	Face Plate Thread Guard (upper) Screw for 52052 and 52103.....
227J	5917	Knife Grinder Knife Stop Screw for 126393.....
228J	5875	Presser Foot Extension Screw for 20157..
228J	5875	" " Strip Gauge Screw for 12435
233J	5892	" " Guide Set Screw for 36714..
236J	5892	Finger Guard Screw for 120859.....
236F	5892	Throat Plate Slide Adjusting Screw for 5732, obsolete.....
237K	1105	Knife Grinder Knife Holder Stop Collar Set Screw for 27659.....
261J	1105	Knife Grinder Knife Regulating Thumb Screw for 60583.....
286D	5875	Arm Side Cover Thumb Screw, obsolete, use 50053D.....
287D	5875	Spool Holder Bracket Thumb Screw, obso- lete, use 51224D.....
287D	5875	Tucker Space Guide Thumb Screw, obsolete, use 51224D.....
307C	5875	Feed Lifting Rock Shaft Screw Center for 56814.....
307C	5875	Feed Rock Shaft Screw Center for 56814..
307C	5875	Tucker Tuck Guide Bracket Screw Center for 56814.....
310K	1105	Knife Grinder Emery Wheel Shaft Screw Center for 60583.....
310K	1105	Knife Grinder Knife Holder Guide Bar Bracket Screw Center for 60583.....
313C	5875	Feed Bar Screw Center for 56813.
356C	5875	Rock Shaft Knee Arm Hub Set Screw for 2766.. ..
356C	5875	Rock Shaft Knee Plate Set Screw for 2767
356C	5875	" " Lifting Arm Set Screw for 2769.....
356C	5875	Rock Shaft Lifting Bracket Hook Set Screw for 6337.....

No.	Plate	Name
356C	5875	Rock Shaft Lifting Bracket Set Screw for 6337.....
356C	5875	Rock Shaft Stop Dog Set Screw for 2770...
362C	21855	Lifting Rod Collar Set Screw for 2762...
375C	5852	Feed Connecting Link Hinge Screw.....
375C	5852	" Forked Connection Hinge Screw.....
375C	5852	" Lifting Rock Shaft Connecting Rod Hinge Screw.....
389D	5889	Spool Holder Base Screw for 95-1 and 95-2 Machines.....
402D	5885	Tucker Space Guide Base Screw for 36395 and 36670.....
418E	2834	Bobbin Winder Tension Screw Stud for 27308.....
423C	5885	Tucker Tuck Guide Bracket Stop Screw for 36394.....
432C	5898	Arm Shaft (upright) Bushing (lower) Set Screw for 95-10 to 95-12 Machines...
435C	5861	Arm Shaft Flanged Bushing (front) Set Screw for 95-1 and 95-2 Machines...
435C	5861	Arm Shaft (horizontal) Flanged Bushing (front) Set Screw for 95-10 to 95-12 Machines.....
435C	5861	Thread Take-up Lever Link Hinge Pin Set Screw.....
446C	21855	Arm Shaft (horizontal) Flanged Bushing (back) Set Screw for 95-10 to 95-12.
447C	5871	Rotating Hook Shaft Bushing (back) Set Screw for 95-1 and 95-2 Machines....
448C	5872	Arm Shaft Flanged Bushing (back) Set Screw for 95-1 and 95-2 Machines....
448C	5872	Balance Wheel Set Screw for 52005 and 52081.....
448C	5872	Feed and Feed Lifting Eccentric Set Screw for 24035 and 52137.....
448C	5872	Lifting Lever Pin Set Screw for 16510 and 16585.....
448C	5872	Thread Take-up Spring Regulator Set Screw.....
453C	5852	Presser Bar Guide Bracket Set Screw for 20059 and 52338.....
457C	5889	Bobbin Winder Frame Hinge Pin Set Screw for 41583.....
457C	5889	Bobbin Winder Stop Latch Hinge Stud Set Screw for 41913.....
460C	5872	Bobbin Winder Tension Stud Set Screw for 41591.....
460C	5872	Thread Eyelet Set Screw for 29642.....
460C	5872	" Retainer Set Screw for 95-10 to 95-12 Machines, obsolete.....

NUMERICAL LIST OF PARTS

No.	Plate	Name
462C	5852	Feed Lifting Rock Shaft Crank (back) Set Screw for 16556.....
578D	5912	Throat Plate Cutting Bar Screw for 5732, 52128 and 52132.....
578D	5912	Throat Plate Slide Adjusting Screw for 52128 and 52132.....
590J	5889	Hemmer Adjusting Screw for 35540.....
591F	5869	Rotating Hook Bobbin Case Tension Regulating Screw for 40395, 52236 and 52481.....
592E	5869	Rotating Hook Bobbin Case Latch Stop Screw for 40395, 52237 and 52473....
620C	21855	Knife Adjusting Screw for 52108.....
621J	21855	" Bar Lifting Spring Guide Bracket Screw for 52107.....
624C	5922	Thread Retainer Set Screw for 95-10 to 95-12 Machines.....
647C	21855	Knife Bar Driving Crank Bracket Screw for 95-12 Machine.....
665J	5892	Presser Foot Spring Guide Screw for 36465.....
688J	5875	Pressure Regulating Thumb Screw for 95-1, 95-2, 95-10 and 95-11 Machines.....
689C	5852	Presser Bar Lifter Hinge Screw.....
691F	5875	Spool Holder Thread Guiding Disc Screw for 26764.....
691F	5875	Throat Plate Screw.....
704J	5869	Rotating Hook Bobbin Case Holder Position Bracket Screw.....
725E	5875	Bed Slide Spring Screw for 12432.....
732D	5875	Guide Thumb Screw for 95-1 and 95-10 Machines, obsolete, use 50190W.....
766D	5875	Lifting Lever Link Hinge Screw for 52029, 52030, 52038, 52116 and 52117.....
775E	5861	Needle Bar Connecting Link Cap Screw for 52143.....
794E	5861	Needle Bar Connecting Link Adjusting Screw for 24040.....
802D	5875	Lifting Lever Hinge Screw for 52029, 52030, 52038, 52116 and 52117.....
803C	5885	Tucker Tuck Guide Frame Stop Screw for 36394.....
818D	5852	Feed Regulator Thumb Screw.....
857C	5861	Needle Set Screw for 52012 and 52129....
858C	5875	Needle Bar Crank Set Screw, obsolete....
868E	5875	Arm Screw (front).....
880E	5889	Bobbin Winder Screw for 41915.....
899J	1105	Knife Grinder Knife Clamping Screw for 27658, 27681 and 126393.....
966E	5889	Feed Lifting Rock Shaft Connecting Rod Cap Screw for 12430.....

NUMERICAL LIST OF PARTS

No.	Plate	Name
970D	4761	Bed Frame Thumb Screw for 24108.....
1036C	5861	Arm Shaft (horizontal) Gear Set Screw for 52060.....
1036C	5861	Thread Take-up Crank Set Screw for 52015 and 52112.....
1037C	5861	Thread Take-up Crank Position Screw for 52015 and 52112.....
1053E	5869	Rotating Hook Thread Guard Screw for 52076 and 52123.....
1065C	5875	Needle Bar Crank Position Screw for 52015 and 52112.....
1072F	21855	Needle Set Screw for 52109.....
1115F	5885	Tucker Tuck Guide Screw for 36394.....
1128E	5852	Feed Regulator Hinge Screw.....
1133E	5861	Needle Bar Bushing (lower) Set Screw....
1133E	5861	" " " (upper) Set Screw....
1143C	5917	Rotating Hook Shaft Bushing (back) Set Screw for 95-10 to 95-12 Machines..
1147C	5889	Rotating Hook Belt Pulley (lower) Position Screw for 40261 and 52040, obsolete.....
1147C	5889	Rotating Hook Belt Pulley (lower) Set Screw for 52048.....
1148C	5871	Rotating Hook Shaft Bushing (front) Set Screw for 95-10 to 95-12 Machines and obsolete for 95-1 and 95-2 Machines.....
1149C	5875	Arm Shaft (upright) Bushing (upper) Set Screw for 95-10 to 95-12 Machines..
1162C	21855	Knife Bar Crank Coupling Pin for 24432..
1177D	5885	Tucker Tuck Guide Arm Screw for 36394....
1253C	5869	Arm Shaft (upright) Gear (lower) Set Screw for 56013.....
1253C	5869	Arm Shaft (upright) Gear (upper) Set Screw for 56101.....
1253C	5869	Rotating Hook Set Screw for 52076 and 52121.....
1253C	5869	Rotating Hook Shaft Gear Set Screw for 56013.....
1274C	5872	Tension Screw Stud for 95-1, 95-2, 95-10 and 95-11 Machines, obsolete.....
1299C	5917	Feed and Feed Lifting Eccentric Position Screw for 52137.....
1362C	5871	Rotating Hook Belt Pulley (upper) Set Screw for 52017, 52041 and 52050....
1367E	5869	Rotating Hook Section Screw for 52076, 52089, 52298 and 127060.....
1380E	5869	Rotating Hook Bobbin Case Tension Spring Screw for 40395, 52236 and 52481....
1426E	5885	Tucker Space Guide Stop (left) Screw Stud for 35510.....

NUMERICAL LIST OF PARTS

No.	Plate	Name
1426E	5885	Tucker Space Guide Stop (right) Screw Stud for 35510.....
1429D	2834	Bobbin Winder Frame Hinge Screw for 60456.....
1430D	2834	Bobbin Winder Stop Latch Hinge Screw for 60456.....
1430D	2834	Bobbin Winder Stop Latch Lever Hinge Screw for 60456.....
1443B	5889	Hemmer Screw for 35540.....
1508J	1105	Knife Grinder Emery Wheel Clamping Nut for 60934.....
1510J	5885	Tucker Tuck Guide Frame Spring Nut for 36394.....
1513J	5872	Feed Lifting Rock Shaft Screw Center Nut for 56814 and 95-10 to 95-12 Machines.....
1513J	5872	Feed Rock Shaft Screw Center Nut for 56814 and 95-10 to 95-12 Machines...
1513J	5872	Tucker Tuck Guide Bracket Screw Center Nut for 56814.....
1516J	1105	Knife Grinder Emery Wheel Shaft Screw Center Nut for 60583.....
1516J	1105	Knife Grinder Knife Holder Guide Bar Bracket Screw Center Nut for 60583..
1518J	5852	Feed Connecting Link Hinge Screw Nut....
1518J	5852	" Forked Connection Hinge Screw Nut..
1518J	5852	" Lifting Rock Shaft Connecting Rod Hinge Screw Nut.....
1519J	5872	Feed Bar Screw Center Nut for 56813.....
1520J	5852	Presser Bar Lifter Hinge Screw Nut.....
1520J	5852	Tucker Tuck Guide Bracket Stop Screw Nut for 36394.....
1520J	5852	Tucker Tuck Guide Frame Stop Screw Nut for 36394.....
1521E	4761	Lifting Lever Connecting Rod Lock Nut for 52029, 52030, 52038, 52116 and 52117.....
1550J	2834	Bobbin Winder Stop Latch Hinge Screw Nut for 60456.....
1560C	5872	Tension Regulating Thumb Nut for 52098..
1562J	2834	Bobbin Winder Tension Regulating Thumb Nut for 27308.....
1564D	21855	Knife Bar Crank Coupling Pin Head for 24432.....
1657D	5885	Tucker Space Guide Stop (left) Thumb Nut for 36398.....
1657D	5885	Tucker Space Guide Stop (right) Thumb Nut for 36398.....
1313	5852	Feed Lifting Rock Shaft Crank (front) Roller and Stud for 12376.....

NUMERICAL LIST OF PARTS

No.	Plate	Name
1813	5852	Feed Lifting Rock Shaft Crank Roller and Stud for 12376.....
2022	21856	Knife Bar Crank Pin for 52106.....
2049	5852	Feed Lifting Rock Shaft Crank (back) Pin for 95-1 and 95-2 Machines, obsolete, use 3093.....
2102	3471	Bobbin Winder Tension Disc for 225462...
2102	3471	Tension Disc for 52092.....
2103	21856	" Spring for 95-10 and 95-11 Machines, obsolete.....
2106	2834	Bobbin Winder Tension Thread Guide for 27308.....
2291	21856	Knife Screw Washer for 52108.....
2297	21856	" Bar Crank Coupling Pin Spring for 24432.....
2301	21856	Knife Bar Stop Pin for 52104.....
2455	2834	Bobbin Winder Tension Disc for 27308 and 41592.....
2523	21856	Knife Bar Lifting Spring Guide Pin for 24906.....
2532	5873	Presser Foot Hinge Pin, obsolete.....
2759	5877	Lifting Rod with 2761 for 2760.....
2760	-----	Lifting Rod complete for 19168, Nos. 2759 and 2762.....
2761	5872	Lifting Rod Cap (washer) for 2759.....
2762	21858	" " Collar with 362C for 2760...
2763	5876	Rock Shaft for 2777, 4880 and 19168....
2765	5877	" " Knee Arm for 2768.....
2766	5877	" " " Hub with 356C for 2768 and 6336.....
2767	5877	Rock Shaft Knee Plate with 356C for 2768 and 6336.....
2768	-----	Rock Shaft Knee Arm complete for 2777 Nos. 2765 to 2767.....
2769	5877	Rock Shaft Lifting Arm with 356C for 19168.....
2770	5876	Rock Shaft Stop Dog with 356C for 2777, 4880 and 19168.....
2777	5877	Rock Shaft complete for 52030 and 52117, Nos. 2763, 2768, 2770, 2778, 6337 and two 12242.....
2778	5877	Rock Shaft Lifting Bracket Hook for 2777
2974	5869	Rotating Hook Bobbin Case Latch Lever Fulcrum Pin for 40393.....
2975	5869	Rotating Hook Bobbin Case Latch Spring for 40395, 52237 and 52473.....
3033	5852	Feed Connecting Link, obsolete, use 52165.....
3039	5852	Feed Regulator for 95-1 and 95-2 Machines
3093	5917	Feed Lifting Rock Shaft Crank (back) Pin for 16588.....

No.	Plate	Name
3146	5873	Guide Thumb Screw Washer for 95-2 and 95-11 Machines.....
4307	5870	Bed Slide Spring for 12432.....
4879	5878	Chain Connecting Link for 4885.....
4880	5876	Rock Shaft complete for 52029 and 52116, Nos. 2763, 2770, 7125, 12243 and two each 6337 and 12242.....
4881	5876	Treadle for 4885.....
4882	5878	" Shaft for 4885.....
4883	5878	" Spring for 4885.....
4884	5876	" Stand for 4885.....
4885	5876	Treadle complete for 52029 and 52116, Nos. 4879, 4881 to 4884 and two wood screws 1 in. No.16.....
5596	5878	Bell Crank for 56848.....
5598	5878	Bell Crank complete for 52029, 52030, 52038, 52116 and 52117, Nos. 5735 and 56848.....
5599	5876	Bell Crank Bracket for 56848.....
5601	4761	" " Hinge Pin for 56848.....
5670	-----	Chain, length 26 in. to 35 in. with 56864 and 56865 for 52029 and 52116.....
5726	21858	Knife for 95-12 Machine.....
5729	-----	Throat Plate Body for 5732, obsolete....
5730	5912	" " Cutting Bar (small needle hole) for 5732 and 52128.....
5731	5912	Throat Plate Slide for 5732, 52128 and 52132.....
5732	5912	Throat Plate complete, for 19103 and 24573 for 95-12 Machine, Nos. 5729, to 5731 and two 578D, obsolete.....
5735	4761	Bell Crank Spring for 5598.....
6267	5873	Hemmer Folder for 36122.....
6335	5877	Rock Shaft Knee Arm for 6336.....
6336	-----	Rock Shaft Knee Arm complete for 19168, Nos. 2766, 2767 and 6335.....
6337	5876	Rock Shaft Lifting Bracket with two 356C for 2777 and 4880.....
7125	5876	Rock Shaft Lifting Bracket Hook for 4880
7298	5873	Presser Foot Hinge Pin for 20270.....
7336	5872	Thread Take-up Spring Regulator, obsolete
7958	21856	Bobbin Winder Stop Latch Stop Pin for 60845.....
8879	21856	Arm Pool Pin Washer (cloth).....
8879	21856	Bobbin Winder Tension Bracket Spool Pin Washer (cloth).....
8908	5879	Wrench for 1519 and 1520 (Accessories)..
8909	5879	" " 1513 and 1518 (Accessories)..
9261	4761	Bed Frame Hinge Connection Pin for 24108
9331	2834	Bobbin Winder Washer for 41347.....

No.	Plate	Name
10141	2834	Bobbin Winder Tension Spring for 27308..
*11104	-----	Arm Shaft Bushing (front) for 52001, obsolete.....
11167	5870	Presser Bar Spring.....
11170	5873	" " " Washer.....
11204	5861	Thread Take-up Lever Link Hinge Pin for 52054.....
11241	2833	Bobbin Winder Spool Washer (cloth) for 27308.....
11833	21856	Knife Grinder Knife Position Pin (upper) for 27681.....
12143	5864	Presser Foot for 44252 and 44253 for 95-1 and 95-10 Machines.....
12144	5864	Presser Foot for 20117, 20132, 20138, 20147, 20151, 20159 and 20162 for 95-1 and 95-10 Machines.....
12193	5870	Arm Side Cover.....
12240	21856	Lifting Lever Pin for 52029, 52030, and 52038.....
12241	21856	Lifting Lever Link for 52029, 52030, 52038, 52116 and 52117.....
12242	5876	Rock Shaft Hanger with two wood screws 1 in. No. 10 for 2777, 4880 and 19168.
12243	5876	Rock Shaft Lifting Bracket Hook for 4880
12260	5864	Presser Foot for 12450, 20147 and 20348 for 95-1 and 95-10 Machines.....
12261	5864	Presser Foot for 20162 for 95-1 and 95-10 Machines.....
12327	5852	Presser Bar Lifting and Releasing Lever Bracket.....
12329	5872	Tension Releasing Lever Spring.....
12335	5865	Presser Foot (narrow) for 95-2 and 95-11 Machines.....
12361	4761	Machine Hinge Connection for 44140.....
12369	5855	Feed Dog, for cloth, 12 teeth (12 teeth to the inch) for 20190 and 20191, obsolete.....
12376	5852	Feed Lifting Rock Shaft Crank 52271 with 157J and 1813 for 52066.....
12376	5852	Feed Lifting Rock Shaft Crank 52271 (front) with 157J and 1813 for 16588
12391	5870	Presser Bar (hollow).....
12398	5872	Tension Releasing Lever Hinge Pin.....
12403	5873	Arm Spool Pin and Thread Eyelet for 52043 for 95-1 and 95-2 Machines....
12403	5873	Bobbin Winder Tension Bracket Spool Pin and Thread Eyelet for 41592.....
12405	4761	Machine Rest (felt) Accessories.....
12411	21859	Throat Plate (large needle hole) for 12457 for 95-1 to 95-10 Machines, obsolete.....

No.	Plate	Name
12416	4761	Lifting Lever Connecting Rod Joint for 52029, 52030, 52038, 52116 and 52117...
12430	5851	Feed Lifting Rock Shaft Connecting Rod with two 966E.....
12431	-----	Bed Slide for 12432.....
12432	5870	Bed Slide complete, Nos. 4307, 12431 and two 725E.....
12435	5865	Presser Foot with 228J for 95-2 and 95-11 Machines.....
12450	5855	Feed Dog, for cloth, 11 teeth (18 teeth to the inch) for 20135 and 20136 for 95-1 and 95-10 Machines.....
12454	5873	Arm Oil Tube with 132590 for oiling Thread Take-up Lever Link.....
12457	5855	Feed Dog, for cloth, 16 teeth (16 teeth to the inch) for 12411, 20190 and 20191, obsolete.....
12462	5866	Presser Foot for 1/8 in. to 1 in. gauges for 95-2 and 95-11 Machines.....
12463	5866	Presser Foot with Strip Guide for 95-2 and 95-11 Machines.....
12480	5850	Arm Side Cap for 95-1, 95-2, 95-10 and 95-11 Machines.....
13710	5872	Tension Spring for 52092.....
*15404	-----	Trade Mark for 52077, 52079 and 52100...
15405	-----	" " Rivet for 52077, 52079 and 52100.....
16504	5851	Feed Lifting Rock Shaft for 16588.....
16506	5851	" Rock Shaft for 24376.....
16510	5878	Lifting Lever with 448C for 52029, 52030 and 52038.....
16532	5873	Arm Dowel Pin.....
16556	5852	Feed Lifting Rock Shaft Crank (back) with 462C for 16588.....
16564	21863	Knife Bar Driving Crank Bracket for 52106.....
16585	21857	Lifting Lever with 448C for 52116 and 52117.....
16586	21862	Lifting Lever Pin for 52116 and 52117...
16588	-----	Feed Lifting Rock Shaft complete for 95-1 and 95-2 Machines, Nos. 3093, 12376, 16504 and 16556.....
17718	5885	Tucker Space Guide Stop (left) Thumb Nut Washer for 36388.....
17718	5885	Tucker Space Guide Stop (right) Thumb Nut Washer for 36388.....
18130	5873	Arm Oil Tube with 52045, for oiling Thread Take-up Lever.....
19066	5879	Spool Holder Spindle for 26764.....
19067	5879	" " Thread Guiding Disc for 26764.....

No.	Plate	Name
19103	5912	Feed Dog, 12 teeth (16 teeth to the inch) for 5732, obsolete.....
19168	-----	Rock Shaft complete for 52038, Nos. 2760, 2763, 2769, 6336 and two each 2770 and 12242.....
19223	-----	Presser Foot Shank for 20134.....
19335	-----	" " " for 20361.....
19392	5912	" " for 3/16 in. gauge and above for 19103 and 24573 for 95-12 Machine.....
20059	5852	Presser Bar Guide Bracket with 453C for 95-1 and 95-2 Machines.....
20060	5872	Slack Thread Regulator for 95-1 and 95-2 Machines and obsolete for 95-10 and 95-11 Machines, use 52337.....
20117	5853	Feed Dog, for shirt work, beveled for hemmer, 16 teeth (16 teeth to the inch) for 20124, 20125, 36122, 120803 to 120807 and 120938.....
20118	5862	Presser Foot, for general work, for 12450 for 95-1 and 95-10 Machines...
20123	5857	Throat Plate for 20163 and 20164 for 95-1, 95-2, 95-10 and 95-11 Machines..
20124	5853	Throat Plate, large needle hole, for 20117 and 20132 for 95-1 and 95-10 Machines.....
20125	-----	Throat Plate, small needle hole, for 20117 and 20132 for 95-1 and 95-10 Machines.....
20132	5853	Feed Dog, for shirt work, beveled for hemmer, 22 teeth (22 teeth to the inch) for 20124, 20125, 36122, 120803 to 120807 and 120938.....
20133	-----	Presser Foot Plate for 20134.....
20134	5866	Presser Foot (hinged) complete for 3/16 in. to 1/4 in. gauges for 95-2 and 95-11 Machines, Nos. 19223, 20133 and 26276.....
20135	5855	Throat Plate, large needle hole, for 12450 and 20348 for 95-1 and 95-10 Machines.....
20136	-----	Throat Plate, small needle hole, for 12450 and 20348 for 95-1 and 95-10 Machines.....
20138	5855	Feed Dog, for shirt work, beveled for hemmer, 13 teeth (12 teeth to the inch) for 20139 and 20140.....
20139	5855	Throat Plate, large needle hole, for 20138 and 20162 for 95-1 and 95-10 Machines.....

From the library of: Harpoon Needle Co.

NUMERICAL LIST OF PARTS

No.	Plate	Name
20140	-----	Throat Plate, small needle hole, for 20138 and 20162 for 95-1 and 95-10 Machines.....
20142	5853	Feed Dog, for general work, 13 teeth (16 teeth to the inch) for 20143 and 20144.....
20143	5853	Throat Plate, large needle hole, for 20142 for 95-1 and 95-10 Machines...
20144	-----	Throat Plate, small needle hole, for 20142 for 95-1 and 95-10 Machines...
20147	5853	Feed Dog, 12 teeth (14 teeth to the inch) for 20148 and 20149.....
20148	5853	Throat Plate, large needle hole, for 20147 and 44177 for 95-1 and 95-10 Machines.....
20149	-----	Throat Plate, small needle hole, for 20147 and 44177 for 95-1 and 95-10 Machines.....
20150	21860	Presser Foot for 20142 for 95-1 and 95-10 Machines.....
20151	5854	Feed Dog, for shirt work, beveled for hemmer, 13 teeth (14 teeth to the inch) for 20152 and 20153.....
20152	5854	Throat Plate, large needle hole, for 20151 and 44144 for 95-1 and 95-10 Machines.....
20153	-----	Throat Plate, small needle hole, for 20151 and 44144 for 95-1 and 95-10 Machines.....
20155	-----	Presser Foot Plate for 20157.....
20156	-----	" " Shank for 20157.....
20157	5865	Presser Foot (hinged) complete for 95-2 and 95-11 Machines, Nos. 228J, 20155, 20156 and 62527.....
20159	5854	Feed Dog, for shirt work, 16 teeth (16 teeth to the inch) for 20160 and 20161.....
20160	5854	Throat Plate, large needle hole, for 20159 for 95-1 and 95-10 Machines...
20161	-----	Throat Plate, small needle hole, for 20159 for 95-1 and 95-10 Machines...
20162	5855	Feed Dog, for shirt work, beveled for hemmer, 17 teeth (16 teeth to the inch) for 20139 and 20140.....
20163	5857	Feed Dog, for 1/16 in. stitch, 16 teeth (16 teeth to the inch) for 20123 and 35540 for 95-1, 95-2, 95-10 and 95-11 Machines.....
20164	5857	Feed Dog, for 1/8 in. stitch, 16 teeth (16 teeth to the inch) for 20123 for 95-2 and 95-11 Machines.....

NUMERICAL LIST OF PARTS

No.	Plate	Name
20190	5855	Throat Plate (large needle hole) for 12369 and 12457 for 95-1 and 95-10 Machines, obsolete.....
20191	-----	Throat Plate (small needle hole) for 12369 and 12457 for 95-1 and 95-10 Machines, obsolete.....
20268	-----	Presser Foot Plate for 20270.....
20269	-----	" " Shank for 20270.....
20270	5862	Presser Foot (hinged) complete for 44252 and 44253 for 95-1 and 95-10 Machines, Nos. 7298, 20268 and 20269..
20325	5854	Feed Dog, for shirt work, 17 teeth (16 teeth to the inch) for 20326 and 20327.....
20326	5854	Throat Plate, large needle hole, for 20325 for 95-1 and 95-10 Machines...
20327	-----	Throat Plate, small needle hole, for 20325 for 95-1 and 95-10 Machines...
20342	21860	Presser Foot for 12450 and 20348 for 95-1 and 95-10 Machines.....
20343	5865	Presser Foot with guide on bottom to the right of needle hole for 95-2 and 95-11 Machines.....
20344	-----	Presser Foot Plate for 20346.....
20345	-----	" " Shank for 20346.....
20346	5862	Presser Foot (spring hinged) complete for 20117, 20138, 20147, 20151 and 20162 for 95-1 and 95-10 Machines, Nos. 20344, 20345, 26231 and 62527..
20348	5855	Feed Dog, for chiffon, 22 teeth (36 teeth to the inch) for 20135 and 20136.....
20360	-----	Presser Foot Plate for 20361.....
20361	5866	Presser Foot (hinged) plain bottom complete for 95-2 and 95-11 Machines, Nos. 19335, 20360 and 26276.....
20472	-----	Presser Foot Plate for 20474.....
20473	-----	" " Shank for 20474.....
20474	5862	Presser Foot (spring, hinged) complete for fine silk, etc. for 95-1 and 95-10 Machines, Nos. 20472, 20473, 26231 and 62527.....
21351	5852	Feed Regulator Thumb Screw Stop for 95-2 and 95-11 Machines.....
24035	5851	Feed and Feed Lifting Eccentric with 448C for 95-1, 95-2 and 95-12 Machines and obsolete for 95-10 and 95-11 Machines, use 52137.....
24036	5851	Feed and Feed Lifting Eccentric Sleeve..
24037	5851	" Forked Connection.....

No.	Plate	Name
*24040	5861	Needle Bar Connecting Link with 794E, for 24894.....
24041	5861	Needle Bar Connecting Stud with 207E, for 24894.....
24079	5877	Drip Pan.....
24106	4761	Bed Frame Cushion (felt) for 24108.....
24107	4761	" " Hinge Connection for 24108....
24108	5876	Bed Frame complete, Nos. 970D, two each 9261, 24107, four each 158E, 24106 and six wood screws 1 1/4 in. No. 12
24109	21862	Knife Holder Handle for 52107.....
24122	21856	" Bar Lifting Spring for 95-12 Machine.....
24123	21858	Knife Bar Lifting Spring Case for 95-12 Machine.....
*24124	21856	Knife Bar Lifting Spring Guide for 24906
*24125	21856	" " " " " Bracket for 24906.....
24131	5873	Arm Oil Tube with 52045 for 52003 for 95-1 and 95-2 Machines.....
24131	5873	Arm Oil Tube with 52045, for oiling Feed and Feed Lifting Eccentric Sleeve...
24131	5873	Arm Oil Tube with 52045, for oiling Feed Lifting Rock Shaft Connecting Rod, for 52043 for 95-10 to 95-12 Machines.....
24131	5873	Bobbin Winder Tension Bracket Oil Tube with 52045, for 41592.....
24297	5850	Balance Wheel Oil Cover for 95-1 and 95-2 Machines.....
24376	-----	Feed Rock Shaft complete for 95-1 and 95-2 Machines, Nos. 16506 and 29633.
24431	21863	Knife Bar Crank with 191C, for 24432....
24432	-----	Knife Bar Crank complete for 52106, Nos. 1162C, 1564D, 2297 and 24431.....
24544	-----	Presser Foot Plate for 24983.....
24573	5912	Feed Dog, 24 teeth (32 teeth to the inch) for 5732, obsolete.....
24722	5912	Presser Foot for 1/32 in. to 11/64 in. gauges, for 19103 and 24573 for 95-12 Machine.....
24894	-----	Needle Bar Connecting Link 24040 with 24041, for 52143.....
24906	21856	Knife Bar Lifting Spring Guide 24124 with 2523 and 24125, for 52107.....
24982	-----	Presser Foot Shank, for 24983.....
24983	21860	Presser Foot (spring, hinged) complete for 52031 for 95-1 Machine, Nos. 24544, 24982, 26231 and 62527.....
25446	21856	Bobbin Winder Screw Washer for 41915....

No.	Plate	Name
25866	6449	Guide for 95-1 Machine.....
25873	21863	" (combination) for 95-2 and 95-11 Machines.....
25878	6449	Guide for 95-1 and 95-10 Machine.....
25888	5873	Hemmer Tongue for 36122.....
25967	5089	Presser Foot Strip Gauge for 95-2 and 95-11 Machines.....
26026	5879	Screw Driver (large) Accessories.....
26231	5873	Presser Foot Spring for 20346, 20474 and 24983.....
26276	5873	Presser Foot Hinge Pin for 20134, 20361 and 52036.....
26279	5089	Presser Foot Extension 1/16 in. for 95-2 and 95-11 Machines.....
26280	5089	Presser Foot Extension 1/8 in. for 95-2 and 95-11 Machines.....
26281	5089	Presser Foot Extension 1/4 in. for 95-2 and 95-11 Machines.....
26282	5089	Presser Foot Extension 3/8 in. for 95-2 and 95-11 Machines.....
26283	5089	Presser Foot Extension 1/2 in. for 95-2 and 95-11 Machines.....
26485	5879	Screw Driver (small) Accessories.....
26603	5905	Feed Dog, 20 teeth (16 teeth to the inch) for 26605, 26606, 35208 and 35236...
26605	5905	Throat Plate, large needle hole, for 26603, for 95-1 and 95-10 Machines...
26606	-----	Throat Plate, small needle hole, for 26603, for 95-1 and 95-10 Machines..
26763	5879	Spool Holder Bracket with 219F and 51224D, for 26764.....
26764	5879	Spool Holder Disc complete for 95-2 and 95-11 Machines, Nos. 691F, 19066, 19067 and 26763.....
27306	2834	Bobbin Winder Spool Pin for 27308.....
27307	2833	" " " Stand for 27308.....
27308	2833	Bobbin Winder Spool Stand complete for 41348, Nos. 418E, 1562J, 2106, 10141, 11241, 27306, 27307 and two each 2455 and wood screws 1 in. No. 10...
27323	1105	Knife Grinder Knife Holder Guide Bar for 60583.....
27564	1104	Knife Grinder Frame with 27574, for 60583.....
27565	1104	Knife Grinder Emery Wheel, 2 in. diam. for 60934.....
27567	1105	Knife Grinder Emery Wheel Shaft for 60934.....
27568	1105	Knife Grinder Emery Wheel Shaft Oil Hole Cover (rubber) for 60583.....

From the Internet Archive

No.	Plate	Name
27569	1105	Knife Grinder Emery Wheel Shaft Pulley for 60934.....
27572	1104	Knife Grinder Knife Holder Guide Bar Bracket with 27574, for 60583.....
27573	1105	Knife Grinder Knife Holder Guide Bar Bracket Spring for 60583.....
27574	1105	Knife Grinder Knife Holder Guide Bar Bracket Spring Hook for 27564 and 27572.....
27657	-----	Knife Grinder Knife Holder Body for 27658.....
27658	1105	Knife Grinder Knife Holder complete for 27661, Nos. 899J, 27657 and 27660...
27659	1105	Knife Grinder Knife Holder Stop Collar with 237K, for 60583.....
27660	21856	Knife Grinder Knife Position Pin for 27658.....
27660	21856	Knife Grinder Knife Position Pin (lower) for 27681 and 126393.....
27661	-----	Knife Grinder complete for 95-12 Machine, Nos. 27662, 60583 either 27658, 27681 or 126393 and three wood screws 1 in. No. 10.....
27662	1104	Wrench for 1508 and 1516, for 27661....
27679	-----	Knife Grinder Knife Holder Body for 27681.....
27681	21862	Knife Grinder Knife Holder complete for 27661, Nos. 899J, 11833, 27660 and 27679.....
27739	7234	Thread Cone (wood) for large cones for 225258 and 225396.....
27822	1105	Knife Grinder Emery Wheel Clamping Nut Washer for 60934.....
29532	5861	Needle Bar Oil Cup for 52013.....
29599	5873	Arm Oil Tube Packing (felt) obsolete, use 52045.....
29633	5852	Feed Rock Shaft Crank with 157J, for 24376 and 52069.....
29642	5872	Thread Eyelet (side of arm) for 95-1 and 95-2 Machines, obsolete for 95-10 Machine, use 52171.....
32572	5872	Tension Releasing Disc for 52092.....
32574	5872	" " Pin for 52092.....
34105	5902	Bobbin Winder Frame Hinge Pin for 60845.
35208	1971	Binder on Shank, to turn in both edges for bias or straight binding, for shirts, wrappers, shirt waists, etc., for 95-1 and 95-10 Machines.....
35236	1971	Hemmer on Shank for 7/16 in. hem for 95-1 and 95-10 Machines.....

No.	Plate	Name
35245	21861	Piping Attachment for piping housedresses for 95-1 and 95-10 Machines.....
35510	5884	Tucker Space Guide Base with 35512, 35514 and two 1426E for 36388.....
35511	5885	Tucker Space Guide Indicator for 36388..
35511	5885	" Tuck Guide Indicator for 36394...
35512	5885	" Space Guide Pin for 35510.....
35513	5885	" " " Stop (left) for 36388
35514	5885	" " " " " Guide Pin for 35510.....
35515	5885	Tucker Space Guide Stop (right) for 36388.....
35517	5883	Tucker Tuck Guide Arm for 36394.....
35518	5883	" " " Base for 36394.....
35524	5885	" " " Frame Spring Washer for 36394.....
35525	5883	Tucker Tuck Guide Plate for 36394.....
35528	5886	Presser Foot (wide) for 36395.....
35540	21861	Hemmer on Shank complete, with right hand lower guide, for lace, for 95-1 and 95-10 Machines, Nos. 1443B, 35926, 35927 and two 590J.....
35682	21860	Hemmer (foot) 1/8 in. hem with guide on bottom to the right of needle hole for 95-1 and 95-10 Machines.....
35710	-----	Hemmer (foot) 3/32 in. hem, with guide on bottom to the right of needle hole, for 95-1 and 95-10 Machines...
35926	-----	Hemmer for 35540.....
35927	-----	" Shank for 35540.....
35997	-----	" (foot) 3/16 in. hem, with guide on bottom to the right of needle hole, for 95-1 and 95-10 Machines.....
36072	-----	Hemmer (foot) 1/4 in. hem, with guide on bottom to the right of needle hole, for 95-1 and 95-10 Machines.....
36118	-----	Hemmer (foot) 3/32 in. hem, for 95-1 and 95-10 Machines, obsolete.....
36119	21860	Hemmer (foot) 1/8 in. hem, for 95-1 and 95-10 Machines, obsolete.....
36120	-----	Hemmer (foot) 5/32 in. hem, for 95-1 and 95-10 Machines, obsolete.....
36121	-----	Hemmer (foot) 3/16 in. hem, for 95-1 and 95-10 Machines, obsolete.....
36122	-----	Hemmer (foot) 7/32 in. hem, for 95-1 and 95-10 Machines.....
36162	-----	Hemmer (foot) 3/32 in. hem, for China silk, etc., for 95-1 and 95-10 Machines.....

No.	Plate	Name
36309	-----	Hemmer (foot) 7/32 in. hem, with guide on bottom to the right of needle hole for 95-1 and 95-10 Machines....
36387	5884	Tucker Space Guide for 36388.....
36388	-----	Tucker Space Guide complete for 36395 and 36670, Nos. 51224D, 35510, 35511, 35513, 35515, 36387 and two each 1657D and 17718.....
36389	5883	Tucker Tuck Guide Bracket for 36394.....
36390	5885	" " " " Spring for 36394
36391	5884	" " " " " Plate for 36394.....
36392	5883	Tucker Tuck Guide Frame for 36394.....
36393	5885	" " " " Spring for 36394
36394	-----	Tucker Tuck Guide complete for 36395 and 36670, Nos. 9D, 423C, 803C, 1510J, 35511, 35517, 35518, 35524, 25525, 36389 to 36393, 50134E two each 1115F, 1177D, 1520J, 56814 and three wood screws 1 1/4 in. No. 10.....
36395	-----	Tucker (long arm) complete for 95-1, 95-2, 95-10 and 95-11 Machines, Nos. 35528, 36388, 36394 and two 402D.....
36413	-----	Hemmer (foot) plain bottom, 1/16 in. hem for 95-1 and 95-10 Machines.....
36414	-----	Hemmer (foot) plain bottom, 3/32 in. hem for 95-1 and 95-10 Machines.....
36416	-----	Hemmer (foot) plain bottom, 3/16 in. hem for 95-1 and 95-10 Machines.....
36434	-----	Hemmer (foot) 3/16 in. hem, for China silk, etc., for 95-1 and 95-10 Machines.....
36464	5892	Presser Foot Spring Guide for 36465.....
36465	5892	" " (right hand, spring guide) with 665J and 36464 for 1/32 in. to 5/16 in. gauges.....
36480	-----	Hemmer (foot) plain bottom, 5/32 in. hem for 95-1 and 95-10 Machines.....
36524	-----	Hemmer (foot) 5/32 in. hem, with guide on bottom to the right of needle hole, for 95-1 and 95-10 Machines.....
36525	21859	Feed Dog, 20 teeth (18 teeth to the inch) for 35682, 35710, 35997, 36072, 36309, 36524 and 36526.....
36526	21859	Throat Plate for 36525 for 95-1 and 95-10 Machines.....
36574	5945	Presser Foot for 36575.....
36575	5945	" " 36574 with 36576 and two 50202J.....
36576	5945	Presser Foot Finger Guard for 36575.....

No.	Plate	Name
36654	5886	Presser Foot for tucking shirt bosoms for 36670.....
36670	-----	Tucker (long arm) complete, for tango tucking, for 95-1, 92-2, 95-10 and 95-11 Machines, Nos. 36388, 36394, 36654 and two 402D.....
36714	-----	Presser Foot with 233J, for 36717.....
36715	5892	" " Guide (right) with 36716, for 36717.....
36716	5892	Presser Foot Guide Stud for 36715.....
36717	5892	Presser Foot complete with Adjustable Guide (right) Nos. 36714 and 36715..
36749	-----	Hemmer (foot) 1/4 in. hem, for 95-1 and 95-10 Machines, obsolete.....
36773	5892	Presser Foot for braiding.....
36818	5945	Finger Guard for 36821.....
36819	5945	" " Friction Washer for 36821..
36820	5945	" " Holder with 196J, for 36821
36821	5945	Finger Guard complete for 95-1, 95-2, 95-10 and 95-11 Machines, Nos. 36818 to 36820 and 50316J.....
40258	5870	Rotating Hook Belt for 95-1 and 95-2 Machines.....
40261	5871	Rotating Hook Belt Pulley (lower, steel) with 1147C, 50143C and sixteen 40263 for 52017, obsolete.....
40263	5871	Rotating Hook Belt Pulley (lower) Stud for 40261 and 52040, obsolete.....
40263	5871	Rotating Hook Belt Pulley (upper) Stud for 52017, 52041 and 52050.....
40264	5869	Rotating Hook Bobbin.....
40274	5869	" " Section for 52076, 52089, 52298 and 127060.....
40276	5871	Rotating Hook Shaft Bushing (back) for 95-1 and 95-2 Machines, obsolete, use 52044.....
40315	5886	Presser Foot, for long stitch, for general work, for 52031, for 95-1 and 95-10 Machines.....
40316	-----	Presser Foot Plate for 40318.....
40317	-----	" " Shank for 40318.....
40318	21860	Presser Foot (hinged) complete, for lace running, for 20163, for 95-1 and 95-10 Machines, Nos. 40316, 40317 and 62527.....
40322	5886	Presser Foot (narrow) for 36395, for 95-1, 95-2, 95-10 and 95-11 Machines
40392	5869	Rotating Hook Bobbin Case Latch for 40393.....

No.	Plate	Name
40393	-----	Rotating Hook Bobbin Case Hinge, Nos. 2974, 40392 and 125320 for 40395, 52237 and 52473.....
40394	5869	Rotating Hook Bobbin Case Tension Spring for 40395, 52236 and 52481.....
40395	5869	Rotating Hook Bobbin Case complete for 40408 and 52442, Nos. 591F, 592E, 1380E, 2975, 40393, 40394 and 40431, obsolete, use 52473.....
40396	5869	Rotating Hook Bobbin Case Holder for 40408, obsolete, use 52443.....
40398	5869	Rotating Hook Thread Guard for 52076, obsolete.....
40408	-----	Rotating Hook Bobbin Case 40395 with 40396, obsolete, use 52442.....
40409	5869	Rotating Hook Bobbin Case Latch Lever, obsolete, use 125320.....
40431	-----	Rotating Hook Bobbin Case for 40395, obsolete, use 52472.....
41339	2833	Bobbin Winder Base for 60456.....
41340	2833	" " Frame for 60456.....
41341	2833	" " " Spring for 60456....
41342	2833	" " Pulley with 200F, for 60456
41343	2834	" " Spindle for 60456.....
41344	2834	" " Stop Latch for 60456.....
41345	2834	" " " " Finger for 60456
41346	2834	" " " " Lever for 60456.
41347	2833	" " for 41348, Nos. 60456 and two each 9331 and wood screws 1 in. No. 10.....
41348	-----	Bobbin Winder (swinging automatic, right hand) complete, Nos. 27308 and 41347
41583	5902	Bobbin Winder Frame with 457C, for 60845
41585	5902	" " Pulley with 171J, for 60845
41586	5902	" " Spindle for 60845.....
41587	5902	" " Stop Latch for 60845.....
41588	5902	" " " " Tripping Arm with 185J, for 60845.....
41591	5902	Bobbin Winder Tension Bracket with 460C, for 41592.....
41592	5902	Bobbin Winder Tension Bracket complete for 41916, Nos. 12403, 24131, 41591, 41593 to 41595 and two 2455.....
41593	5873	Bobbin Winder Tension Spring for 41592..
41594	5873	" " " Stud for 41592....
41595	5873	" " " Thread Guide for 41592.....
41913	5902	Bobbin Winder Bracket with 457C, for 60845.....
41914	5902	Bobbin Winder Frame Spring for 60845....

No.	Plate	Name
41915	5902	Bobbin Winder 60845 with 880E and 25446, for 41916.....
41916	-----	Bobbin Winder (swinging automatic, left hand) complete, Nos. 41592 and 41915
42614	5902	Bobbin Winder Stop Latch Hinge Stud for 60845.....
43921	5850	Arm Shaft Flanged Bushing (back) for 95-1 and 95-2 Machines.....
43944	5872	Tension Releasing Lever.....
43946	5872	Thread Take-up Spring, obsolete.....
44139	4761	Machine Hinge Plate for 44140.....
44140	-----	Machine Hinge complete, Nos. 12361, 44139 and merlized wood screw 1 1/4 in. No. 14 (Accessories).....
44144	5854	Feed Dog, beveled for hemmer, 22 teeth (24 teeth to the inch) for 20152 and 20153.....
44177	5853	Feed Dog, 19 teeth (22 teeth to the inch) for 20148 and 20149.....
44252	5856	Feed Dog, for cloth, 12 teeth (12 teeth to the inch) for 44255 and 44256....
44253	5856	Feed Dog, for cloth, 16 teeth (16 teeth to the inch) for 44255 and 44256....
44255	-----	Throat Plate, small needle hole, for 44252 and 44253, for 95-1 and 95-10 Machines.....
44256	5856	Throat Plate, large needle hole, for 44252 and 44253, for 95-1 and 95-10 Machines.....
50053D	21855	Arm Side Cover Thumb Screw.....
50083C	21855	Feed Connecting Link Hinge Stud Set Screw for 52074.....
50117E	5875	Feed Dog Screw.....
50117E	5875	Knife Holder Handle Screw for 52107....
50117E	5875	" " Screw for 52107.....
50134E	5885	Tucker Tuck Guide Base Screw Stud for 36394.....
50143C	5871	Rotating Hook Belt Pulley (lower) Set Screw for 40261, obsolete.....
50145E	5889	Rotating Hook Shaft Bushing (front) Position Screw for 95-1 and 95-2 Machines.....
50190J	21855	Face Plate Thumb Screw.....
50190W	21855	Guide Thumb Screw for 95-1, 95-2, 95-10 and 95-11 Machines.....
50191C	21855	Feed Lifting Rock Shaft Screw Center for 95-10 to 95-12 Machines.....
50191C	21855	Feed Rock Shaft Screw Center for 95-10 to 95-12 Machines.....
50202J	5945	Presser Foot Finger Guard Screw for 36575.....

NUMERICAL LIST OF PARTS

No.	Plate	Name
50234E	21855	Arm Shaft (horizontal) Gear Case Plug Screw for 52071, obsolete.....
50234E	21855	Rotating Hook Shaft Gear Case Plug Screw for 52072.....
50302J	5892	Finger Guard Holder Screw for 120858....
50304C	21855	Tension Stud for 52098.....
50305C	21855	" " Set Screw for 52083.....
50316J	5945	Finger Guard Hinge Screw for 36821.....
50373W	21855	Pressure Regulating Thumb Screw for 95-12 Machine.....
51224D	21855	Spool Holder Bracket Thumb Screw for 26763.....
51224D	21855	Tucker Space Guide Thumb Screw for 36388.....
*52001	-----	Arm with 11104, for 95-1 Machine, obsolete.....
52002	-----	Arm Oil Tube Holder for 52003.....
52003	5873	" " " " 52002 with 24131, for oiling Feed Lifting Rock Shaft Connecting Rod.....
52004	5850	Arm Shaft for 95-1 and 95-2 Machines....
52005	5850	Balance Wheel (power) light rim, 2 3/16 in. pulley, with two 448C.....
*52006	-----	Bed for 95-1 and 95-2 Machines.....
52007	-----	Face Plate for 52008, obsolete.....
52008	5850	Face Plate complete for 95-1 Machine, Nos. 52007, 52009 and 52010, obsolete, use 52052.....
52009	5873	Face Plate Thread Guard (lower) for 52008, obsolete.....
52010	5873	Face Plate Thread Guard (upper) for 52008, obsolete.....
52011	5851	Feed Bar, obsolete, use 52452.....
52012	5861	Needle Bar (hollow) with 857C for 95-1, 95-2, 95-10 and 95-11 Machines, obsolete, use 52129.....
52013	5861	Needle Bar Bushing (lower) with 29532, for 95-1, 95-2, 95-10 and 95-11 Machines.....
52014	5861	Needle Bar Bushing (upper) for 95-1, 95-2, 95-10 and 95-11 Machines.....
52015	5851	Needle Bar Crank with 1036C, 1037C and 1065C, for 95-1, 95-2, 95-10 and 95-11 Machines.....
52016	5852	Presser Bar Lifter.....
52017	5871	Rotating Hook Belt Pulley (upper) with 1362C and thirty 40263, for 40261, for 95-1 and 95-2 Machines, obsolete
52018	5869	Rotating Hook Bobbin Case Holder Position Bracket.....

NUMERICAL LIST OF PARTS

No.	Plate	Name
52019	5870	Rotating Hook Shaft for 95-1 and 95-2 Machines.....
52020	5871	Rotating Hook Shaft Bushing (front) for 95-1 and 95-2 Machines, obsolete, use 52039.....
52021	5861	Thread Take-up Crank for 52143.....
52022	5861	" " Lever with 52130, for 52025
52023	5861	" " " Hinge Pin for 52025.
52024	5861	" " " Link for 52025.....
52025	-----	Thread Take-up Lever complete for 52054, Nos. 52022 to 52024.....
52026	5861	Thread Eyelet for 95-1, 95-2, 95-10 and 95-11 Machines, obsolete, use 52171.
52027	5872	Thread Guard (side of arm).....
52028	5878	Lifting Lever Connecting Rod for 52029, 52030, 52038, 52116 and 52117.....
52029	-----	Foot Lifter complete for 95-1, 95-2, 95-10 and 95-11 Machines, Nos. 76D, 766D, 902D, 1521E, 488C, 488E, 5598, 5670, 1224C, 12241, 12416, 16510, 52028 and two 178E.....
52030	-----	Knee Lifter complete (power table) for 95-1, 95-2, 95-10 and 95-11 Machines, Nos. 76D, 766D, 8C2D, 1521E, 2777, 5598, 1224C, 12241, 12416, 16510, 52028 and two 178E.....
52031	5856	Feed Dog, for shirt work, 19 teeth (22 teeth to the inch) for 36162, 36434, 52032, 52033, 120898 and 120911.....
52032	-----	Throat Plate, large needle hole, for 52031, for 95-1, 95-2, 95-10 and 95-11 Machines.....
52033	5856	Throat Plate, small needle hole, for 52031, for 95-1, 95-2, 95-10 and 95-11 Machines.....
52034	-----	Presser Foot Plate for 52036.....
52035	-----	" " Shank for 52036.....
52036	21860	Presser Foot (hinged) complete for 52031, for 95-1 and 95-10 Machines, Nos. 26276, 52034 and 52035.....
52037	5870	Rotating Hook Belt Guard for 95-1 and 95-2 Machines.....
52038	-----	Knee Lifter complete (bench stand) for 95-1, 95-2, 95-10 and 95-11 Machines, Nos. 76D, 766D, 802D, 1521E, 5598, 1224C, 12241, 12416, 16510, 1916E, 52028 and two 178E.....
52039	5871	Rotating Hook Shaft Bushing (front) for 95-1 and 95-2 Machines.....

No.	Plate	Name
52040	5887	Rotating Hook Belt Pulley (lower, steel) with two 1147C and sixteen 40263, for 52041, obsolete.....
52041	5887	Rotating Hook Belt Pulley (upper) with 1362C and thirty 40263, for 52040, obsolete.....
52042	21862	Arm Top Cover for 52043.....
52043	-----	" " " 52042 with 12403 and 24131, for 95-10 to 95-12 Machines.....
52044	5871	Rotating Hook Shaft Bushing (back) for 95-1 and 95-2 Machines.....
52045	5871	Arm Oil Tube Packing (wick) for 18130, 24131, 52084 and 52120.....
52045	5871	Bobbin Winder Tension Bracket Oil Tube Packing (wick) for 24131.....
52045	5871	Rotating Hook Shaft Bushing (back) Packing (wick).....
52045	5871	Rotating Hook Shaft Bushing (front) Packing (wick).....
52046	21863	Spool Holder Base for 52047.....
52047	21863	Spool Holder complete for 95-1 and 95-2 Machine, Nos. 52046, 200079H and 204296.....
52048	5888	Rotating Hook Belt Pulley (lower, steel) with two 1147C and sixteen 52049, for 95-1 and 95-2 Machines.....
52049	5888	Rotating Hook Belt Pulley (lower) Stud for 52048.....
52050	5888	Rotating Hook Belt Pulley (upper) with 1362C and thirty 40263, for 95-1 and 95-2 Machines.....
52051	-----	Face Plate for 52052.....
52052	5894	Face Plate complete for 95-1, 95-2, 95-10 and 95-11 Machines, Nos. 52051, 52053, 52170 and two 226J.....
52053	21858	Face Plate Thread Guard (lower) for 52052 and 52103.....
52054	-----	Thread Take-up complete, Nos. 11204, 52025 and 52143.....
52055	5905	Presser Foot for 35208 and 35236.....
52056	21860	" " " 35245.....
52058	5895	Arm Shaft (horizontal) for 95-10 and 95-11 Machines, obsolete, superseded by 52141, not interchangeable.....
52059	5894	Arm Shaft (horizontal) Flanged Bushing (back) for 95-10 to 95-12 Machines..
52060	5898	Arm Shaft (horizontal) Gear with two 1036C, for 95-10 to 95-12 Machines..
52062	5898	Arm Shaft (upright) for 95-10 to 95-12 Machines.....

No.	Plate	Name
52063	5894	Balance Wheel Oil Cover for 95-10 to 95-12 Machines.....
*52064	-----	Bed for 95-10 to 95-12 Machines.....
52065	5895	Feed Lifting Rock Shaft for 52066.....
52066	-----	Feed Lifting Rock Shaft complete for 95-10 to 95-12 Machines, Nos. 12376 and 52065.....
52068	5895	Feed Rock Shaft for 52069.....
52069	-----	Feed Rock Shaft complete for 95-10 to 95-12 Machines, Nos. 29633 and 52068
52070	5895	Rotating Hook Shaft 95-10 to 95-12 Machines.....
52071	5894	Arm Shaft (horizontal) Gear Case (two pieces) with 121E and 50234E, for 95-10 to 95-12 Machines, obsolete, superseded by 52151, not interchangeable.....
52072	5894	Rotating Hook Shaft Gear Case (two pieces) with 121E and 50234E, for 95-10 to 95-12 Machines.....
52073	21858	Feed Connecting Link Hinge Stud 95-10 to 95-12 Machines.....
52074	21863	Feed Regulator with 50083C, for 95-10 to 95-12 Machines.....
52076	5869	Rotating Hook with 40274, 40398, two 1253C and three each 1053E and 1362E, for 95-10 Machine, obsolete, use 52089..
*52077	-----	Arm with 15404 and two each 15405 and 56015, for 95-10 and 95-11 Machines.
52078	5894	Arm Shaft Flanged Bushing (front) for 95-1 and 95-2 Machines.....
52078	5894	Arm Shaft (horizontal) Flanged Bushing (front) for 95-10 to 95-12 Machines.
*52079	-----	Arm with 15404 and two 15405, for 95-1 and 95-2 Machines.....
52081	21857	Balance Wheel (stand) heavy rim, 2 11/16 in. pulley, with two 448C.....
52082	21858	Thread Take-up Spring for 52092.....
52083	21862	" " " Regulator with 50305C, for 52092.....
52084	21858	Arm Oil Tube with 52045, for oiling Needle Bar Connecting Link.....
52089	5898	Rotating Hook 52123 with 40274 and three 1367E, for 52124 (For agents only)
52090	5898	Rotating Hook Thread Guard for 52123....
52092	-----	Tension complete, Nos. 13710, 32572, 32574, 52082, 52083, 52098 and two 2102.....
52098	-----	Tension Stud 50304C with 1560C for 52092
*52100	-----	Arm with 15404 and two each 15405 and 56015, for 95-12 Machine.....

No.	Plate	Name
52101	21857	Arm Shaft (horizontal) for 95-12 Machine
52102	-----	Face Plate for 52103.....
52103	21857	Face Plate complete for 95-12 Machine, Nos. 52053,52102,52170 and two 226J.
52104	21863	Knife Bar with 2301, for 52107.....
52105	21863	" " Driving Crank (forked) for 52106.....
52106	-----	Knife Bar Driving Crank Bracket complete for 95-12 Machine, Nos. 2022, 16564, 24432 and 52105.....
52107	-----	Knife Bar complete for 95-12 Machine, Nos. 621J, 24109, 24906, 52104, 52108 and three 50117E.....
52108	21862	Knife Holder with 620C, 2291 and two 223J, for 52107.....
52109	21863	Needle Bar (hollow) with 1072F, with 95-12 Machine.....
52110	21858	Needle Bar Bushing (lower) with 52114, for 95-12 Machine.....
52111	21863	Needle Bar Bushing (upper) for 95-12 Ma- chine.....
52112	21863	Needle Bar Crank (eccentric) with 1036C, 1037C and 1065C, for 95-12 Machine..
52113	21862	Needle Bar Crank (eccentric) Sleeve for 95-12 Machine.....
52114	21858	Needle Bar Oil Cup for 52110.....
52115	21863	Slack Thread Regulator for 95-12 Machine
52116	-----	Foot Lifter complete for 95-12 Machine, Nos. 76D, 766D, 302D, 1521E, 4880, 4885, 5598, 5670, 12241, 12416, 16585, 16586, 52028 and two 178E.....
52117	-----	Knee Lifter complete (power table) for 95-12 Machine, Nos. 76D, 766D, 802D, 1521E, 2777, 5598, 12241, 12416, 16585, 16586, 52028 and two 178E.....
52120	21858	Arm Oil Tube with 52045, for oiling 24040, for 95-12 Machine, obsolete, use 52084.....
52121	-----	Rotating Hook with three 1253C, for 52123.....
52123	-----	Rotating Hook 52121 with 52090 and four 1053E, for 52089, 52298 and 127060..
52124	-----	Rotating Hook 52089 with 52442, obsolete, use 52478.....
52126	5857	Feed Dog, 12 teeth (16 teeth to the inch) for 52128 and 52132, for 95-12 Ma- chine.....
52127	-----	Throat Plate Body for 52128 and 52132...
52128	-----	Throat Plate complete (small needle hole) for 52126, for 95-12 Machine, Nos. 5730, 5731, 52127 and three 578D....

No.	Plate	Name
52129	5916	Needle Bar (hollow) with 857C, for 95-1, 95-2, 95-10 and 95-11 Machines.....
52130	5917	Thread Take-up Lever Thread Eyelet Bush- ing for 52022.....
52131	5357	Throat Plate Cutting Bar (large needle hole) for 52132.....
52132	5857	Throat Plate complete (large needle hole) for 52126, for 95-12 Machine, Nos. 5731, 52127, 52131 and three 578D...
52137	5917	Feed and Feed Lifting Eccentric with 448C and 1299C, for 95-10 and 95-11 Machines.....
52141	5916	Arm Shaft (horizontal) for 95-10 and 95-11 Machines.....
52143	-----	Thread Take-up Crank 52021 with 775E and 24894, for 52054.....
52146	5922	Arm Shaft Flanged Bushing (back) Oil Pad (braided cotton) for 95-1 and 95-2 Machines.....
52146	5922	Arm Shaft Flanged Bushing (front) Oil Pad (braided cotton) for 95-1 and 95-2 Machines.....
52146	5922	Arm Shaft (horizontal) Flanged Bushing (back) Oil Pad (braided cotton) for 95-10 to 95-12 Machines.....
52146	5922	Arm Shaft (horizontal) Flanged Bushing (front) Oil Pad (braided cotton) for 95-10 to 95-12 Machines.....
52148	5922	Arm Oil Tube for 52149.....
52149	-----	" " " 52148 with 52150, for oiling Arm Shaft (horizontal) Gear for 95-10 to 95-12 Machines.....
52150	5922	Arm Oil Tube Packing (braided cotton) for 52149.....
52151	5922	Arm Shaft (horizontal) Gear Case (two pieces) with 121E, for 95-10 to 95-12 Machines.....
52159	5905	Feed Dog, for sheer material, 23 teeth (22 teeth to the inch) for 52160....
52160	5905	Throat Plate, for sheer material, for 52159, for 95-10 Machine.....
52161	5905	Presser Foot, for sheer material, for 52159, for 95-10 Machine.....
52165	21858	Feed Connecting Link.....
52170	21858	Face Plate Thread Guard (upper) for 52052 and 52103.....
52171	21858	Thread Eyelet for 52013.....
52235	-----	Rotating Hook Bobbin Case for 52236.....
52236	21861	" " " " 52235 with 591F, 1380E and 40394, for 52237.....

No.	Plate	Name
52237	-----	Rotating Hook Bobbin Case complete for 52299, 52478, 127099 and 127241, Nos. 592E, 2975, 40393 and 52236.....
*52271	-----	Feed Lifting Rock Shaft Crank for 12376.
*52271	-----	" " " " " (front) for 12376.....
52298	-----	Rotating Hook 52123 with 40274, 127242 and three 1367E, for 52299.....
52299	-----	Rotating Hook 52298 with 52237.....
52337	21863	Siack Thread Regulator for 95-10 and 95-11 Machines.....
52338	21862	Presser Bar Guide Bracket with 223C and 453C, for 95-10 to 95-12 Machines...
52348	-----	Thread Take-up Spring, obsolete.....
52378	21858	" Retaining Stud for 52379, obsolete
52379	-----	Thread Retainer complete for 95-10 to 95-12 Machines, Nos. 52378, 52398, 210958 and 210993, obsolete.....
52398	21858	Thread Retaining Spring for 52379, obsolete.....
52442	-----	Rotating Hook Bobbin Case 40395 with 52443, for 52124, obsolete, use 52474
52443	21861	Rotating Hook Bobbin Case Holder, for 52442, obsolete.....
52452	5916	Feed Bar.....
52454	5917	Thread Retainer for 95-10 to 95-12 Machines.....
52472	-----	Rotating Hook Bobbin Case for 52481, obsolete, use 52235.....
52473	5917	Rotating Hook Bobbin Case complete for 52474, Nos. 592E, 2975, 40393 and 52481, obsolete, use 52237.....
52474	-----	Rotating Hook Bobbin Case 52473 with 52477, obsolete, use 127099.....
52475	5917	Rotating Hook Bobbin Case Locating Plate for 52477, obsolete.....
52476	5917	Rotating Hook Bobbin Case Locating Plate Rivet for 52477, obsolete.....
52477	5917	Rotating Hook Bobbin Case Holder with 52475 and 52476, for 52474, obsolete, use 127100.....
52478	-----	Rotating Hook 127060 with 52237, obsolete, use 52299.....
52481	-----	Rotating Hook Bobbin Case 52472 with 591F, 1380E and 40394, for 52473, obsolete, use 52236.....
54897	21856	Arm Shaft Front Bearing Oil Cup for 95-10 to 95-12 Machines, obsolete, use 68350.....
54897	21856	Rotating Hook Shaft Front Bearing Oil Cup.....

No.	Plate	Name
56006	21856	Arm Shaft Flanged Bushing (back) Oil Pad (braided cotton) for 95-1 and 95-2 Machines, obsolete, use 52146.....
56006	21856	Arm Shaft Flanged Bushing (front) Oil Pad (braided cotton) for 95-1 and 95-2 Machines, obsolete, use 52146..
56006	21856	Arm Shaft (horizontal) Flanged Bushing (back) Oil Pad (braided cotton) for 95-10 to 95-12 Machines, obsolete, use 52146.....
56006	21856	Arm Shaft (horizontal) Flanged Bushing (front) Oil Pad (braided cotton) for 95-10 to 95-12 Machines, obsolete, use 52146.....
56013	5898	Arm Shaft (upright) Gear (lower) with two 1253C, for 95-10 to 95-12 Machines.....
56013	5898	Rotating Hook Shaft Gear with two 1253C, for 95-10 to 95-12 Machines.....
56015	21858	Arm Shaft (upright) Oil Tube (lower) for 52077 and 52100.....
56015	21858	Arm Shaft (upright) Oil Tube (upper) for 52077 and 52100.....
56086	-----	Face Plate Thread Guard (upper) obsolete, use 52170.....
56099	5898	Arm Shaft (upright) Bushing (lower) for 95-10 to 95-12 Machines.....
56100	5898	Arm Shaft (upright) Bushing (upper) for 95-10 to 95-12 Machines.....
56101	5898	Arm Shaft (upright) Gear (upper) with two 1253C, for 95-10 to 95-12 Machines.....
56106	5898	Rotating Hook Shaft Bushing (back) for 95-10 to 95-12 Machines.....
*56107	5898	Rotating Hook Shaft Bushing (front) for 95-10 to 95-12 Machines.....
56213	-----	Feed Bar Screw Center 313C with 1519J...
56814	-----	Feed Lifting Rock Shaft Screw Center 307C with 1513J, for 95-1 and 95-2 Machines.....
56814	-----	Feed Rock Shaft Screw Center 307C with 1513J, for 95-1 and 95-2 Machine....
56814	-----	Tucker Tuck Guide Bracket Screw Center 307C with 1513J, for 36394.....
56848	-----	Bell Crank 5596 with 5599 and 5601, for 5598.....
56864	5917	Chain Hook (large) for 5670.....
56865	5917	" " (small) for 5670.....
60456	-----	Bobbin Winder for 41347, Nos. 152F, 207D, 1429D, 1550J, 41339 to 41346 and three 1430D.....

No.	Plate	Name
*60583	5918	Knife Grinder for 27661, Nos. 261J, 27323, 27564, 27572, 27573, 27659, 60934 two 27568 and four each 310K and 1516J..
60845	-----	Bobbin Winder for 41915, Nos. 7958, 34105, 41583, 41585 to 41588, 41913, 41914 and 42614.....
60934	-----	Knife Grinder Emery Wheel Shaft 27567 with 1508J, 27565, 27569 and 27822, for 60583.....
62527	21861	Presser Foot Hinge Pin for 20157, 20346, 20474, 24983 and 40318.....
68350	5922	Arm Shaft (horizontal) Front Bearing Oil Cup for 95-10 to 95-12 Machines.....
120332	5879	Grease Gun (Accessories.....
120342	5879	Oiler (copper plated) with 120343 (Accessories).....
120343	5879	Oiler Spout, 3 1/2 in. long for 120342..
120803	5919	Hemmer (foot) for 1/8 in. hem for 95-1 and 95-10 Machine.....
120804	5919	Hemmer (foot) for 5/32 in. hem for 95-1 and 95-10 Machines.....
120805	5919	Hemmer (foot) for 3/16 in. hem for 95-1 and 95-10 Machines.....
120806	5920	Hemmer (foot) for 1/4 in. hem for 95-1 and 95-10 Machines.....
120807	5920	Hemmer (foot) for 5/16 in. hem for 95-1 and 95-10 Machines.....
120829	5922	Presser Foot (single toe) for gathering, for fine work.....
120837	5920	Hemmer (foot) plain bottom, 1/8 in. hem, slotted for lace, for 95-1 and 95-10 Machines.....
*120838	5919	Hemmer Tongue for 120804 and 120805.....
*120839	5920	" " " 120806 and 120807.....
*120843	5919	" " " 120803 and 120938.....
120856	5892	Finger Guard for 120859.....
120858	5892	" " Holder with 50302J, for 120859.....
120859	5892	Finger Guard complete for 95-1, 95-2, 95-10 and 95-11 Machines, Nos. 120856, 120858 and two 236J.....
120898	5921	Hemmer (foot) 1/16 in. to 1/8 in. hem, China silk, etc., 95-1 and 95-10 Machines.....
120911	5921	Hemmer (foot) 5/32 in. to 1/4 in. hem, for China silk, etc., for 95-1 and 95-10 Machines.....
120938	5921	Hemmer (foot) for 3/32 in. hem for 95-1 and 95-10 Machines.....
120939	5919	Hemmer Folder for 120803 to 120807 and 120938.....

No.	Plate	Name
125320	21861	Rotating Hook Bobbin Case Latch Lever for 40393.....
126392	5916	Knife Grinder Knife Holder for 126393...
126393	-----	Knife Grinder Knife Holder complete for 27661, Nos. 227J, 899J, 27660, 126392 and 126394.....
126394	5917	Knife Grinder Knife Stop for 126393.....
127060	-----	Rotating Hook 52123 with 40274, 127100 and three 1367E for 52478, obsolete, use 52298.....
127099	-----	Rotating Hook Bobbin Case 52237 with 127100, obsolete, use 127241.....
127100	-----	Rotating Hook Bobbin Case Holder for 127060 and 127099, obsolete, use 127242.....
127241	-----	Rotating Hook Bobbin Case 52237 with 127242.....
127242	21861	Rotating Hook Bobbin Case Holder for 52298 and 127241.....
132590	21856	Arm Oil Tube Packing (wick) for 12454..
150203	20335	Thread Unwinder Spool Rest Cushion (felt) for 225258.....
200056E	3471	Bobbin Winder Stop Latch Screw for 225382.....
200079H	5889	Spool Holder Base Wire Hinge Screw for 52047.....
200082D	3471	Bobbin Winder Tension Bracket Screw for 225382.....
200299H	3471	Bobbin Winder Stop Latch Trip Lever Hinge Screw for 225382.....
200380C	3471	Bobbin Winder Pulley Set Screw for 202473.....
200383C	5917	Thread Unwinder Spool Rest Rod Set Screw for 202490.....
201018C	5917	Thread Unwinder Spool Rest Set Screw for 225257 and 225395.....
201499B	3471	Bobbin Winder Tension Stud for 225461...
201572B	3471	" " " " Thumb Nut for 225462.....
201696J	5917	Thread Unwinder Thread Guide Lock Nut for 225258 and 225396.....
202277	3471	Bobbin Winder Frame Oil Packing (wick) for 225453.....
202407	3471	Bobbin Winder Tension Spring for 225462.
202473	3470	" " Pulley with 200380C. for 225382.....
202478	3471	Bobbin Winder Stop Latch Trip Lever for 225382.....
202490	20335	Thread Unwinder Spool Stand with 200383C, for 225258 and 225396.....

No.	Plate	Name
204296	21863	Spool Holder Base Wire for 52047.....
210958	21856	Thread Retaining Collar for 52379, obsolete.....
210993	21856	Thread Retaining Sleeve for 52379, obsolete.....
225257	20335	Thread Unwinder Spool Rest with 201018C, for 225258.....
225258	20335	Thread Unwinder complete, Nos. 201696J, 202490, 225257, 225324, 225326, 225388, two each 150203, 225391 and three wood screws 7/8 in. No. 12.....
225322	5922	Thread Unwinder Thread Guide Rod Washer for 225324.....
225324	20335	Thread Unwinder Thread Guide Rod with 208E and 225322, for 225258 and 225396.....
225326	5922	Thread Unwinder Thread Guide Position Cup for 225258 and 225396.....
225381	3470	Bobbin Winder Spindle for 225382.....
225382	-----	Bobbin Winder (swinging automatic, right hand) complete for Power Table, Nos. 200056E, 200082D, 200299H, 202473, 202478, 225381, 225433, 225444, 225453 to 225456, 225458, 225462, 228026, two each 225459 and wood screws 3/4 in. No. 12 R.H.....
225388	20335	Thread Unwinder Spool Rest Rod for 225258 and 225396.....
225390	7234	Thread Cone Holder for inverted cones for 225258 and 225396.....
225391	20335	Thread Unwinder Thread Guide for 225258 and 225396.....
225392	-----	Thread Unwinder Thread Guide Rod with 208E and 225393, for 225396, obsolete.....
225393	5917	Thread Unwinder Thread Guide Rod Washer for 225392, obsolete.....
225395	7233	Thread Unwinder Spool Rest with 201018C, for 225396, obsolete.....
225396	7233	Thread Unwinder complete, Nos. 201696J, 202490, 225324, 225326, 225388, 225395, two 225391 and three wood screws 7/8 in. No. 12, obsolete, use 225258....
225433	-----	Bobbin Winder and Tension Bracket Base for 225382.....
225438	3471	Bobbin Winder Frame Oil Well Cap for 225453.....
225444	3471	Bobbin Winder Stop Latch for 225382.....
225453	3470	" " Frame with 202277 and 225438, for 225382.....
225454	3471	Bobbin Winder Frame Hinge Pin for 225382

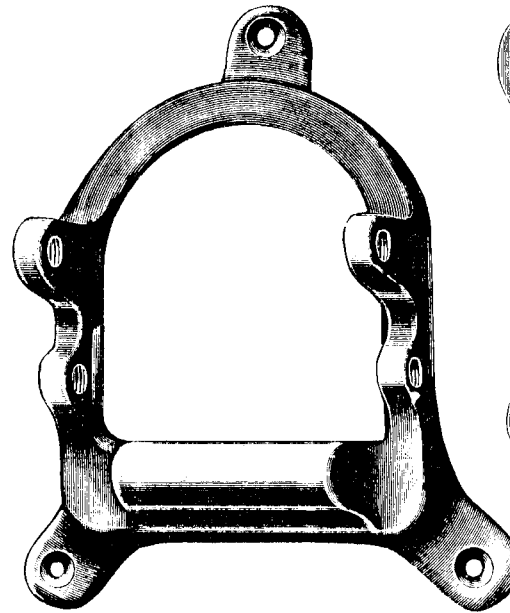
No.	Plate	Name
225455	3471	Bobbin Winder Frame Spring for 225382...
225456	3471	" " " " Plunger for 225382.....
225458	3471	Bobbin Winder Stop Latch Thumb Lever for 225382.....
225459	3471	Bobbin Winder Stop Latch Thumb Lever Hinge Stud for 225382.....
225459	3471	Bobbin Winder Stop Latch Thumb Lever Joint Stud for 225382.....
225460	3471	Bobbin Winder Stop Latch Thumb Lever Joint Stud, obsolete.....
225461	3471	Bobbin Winder Tension Bracket with 201499B, for 225462.....
225462	-----	Bobbin Winder Tension Bracket complete for 225382, Nos. 201572B, 202407, 225461 and two 2102.....
228026	-----	Bobbin Winder Tension Bracket Screw Washer for 225382.....

SINGER Needles should be used
in **SINGER** Machines
These Needles and their Containers
are marked with the
Company's Trade Mark "**SIMANCO**."** 1

Needles in Containers marked
"**FOR SINGER MACHINES**"
are **NOT SINGER** made needles. 2

PLATE 1104—ONE-HALF SIZE

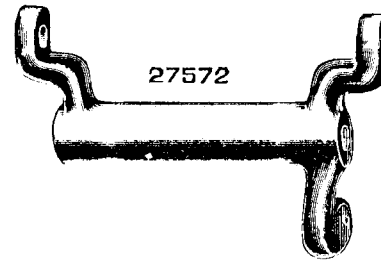
27564



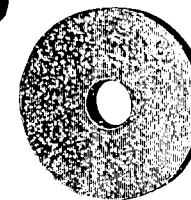
27662



27572



27565



From the library of: Diamond Needle Corp

PLATE 1105—FULL SIZE

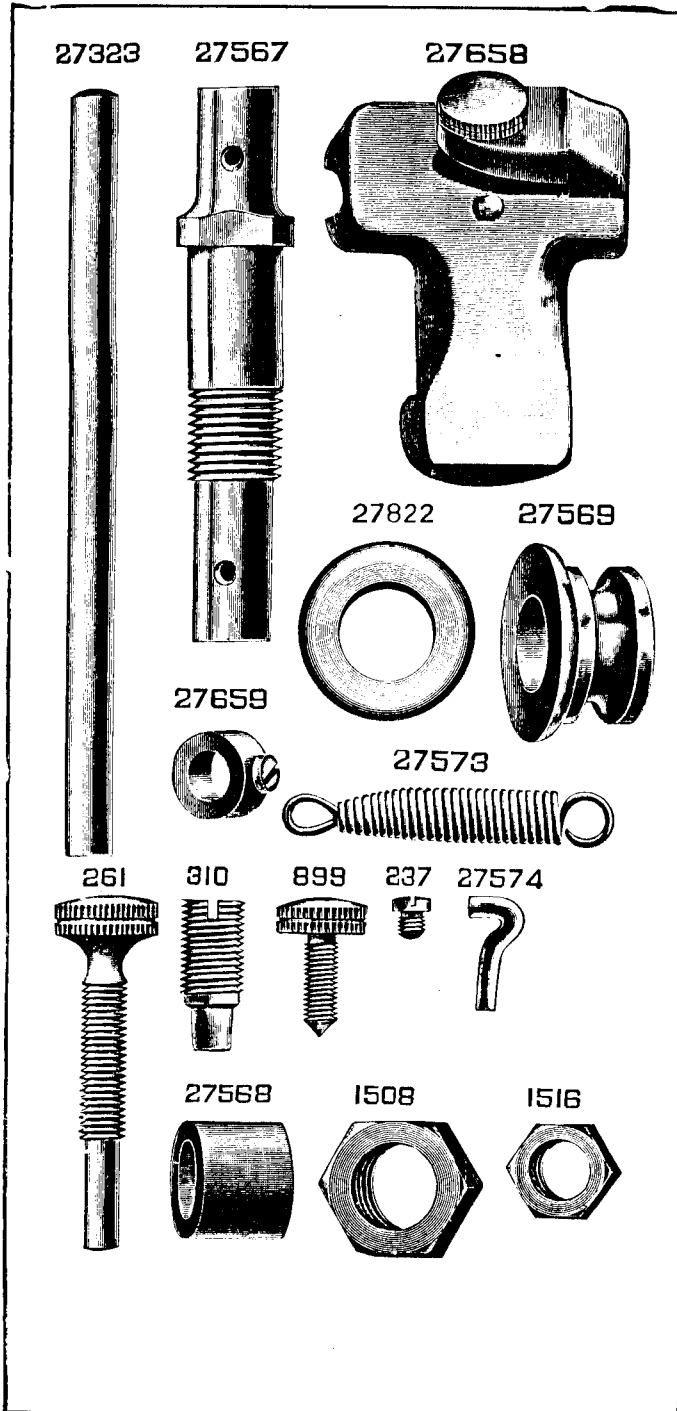


PLATE 1971—ONE-HALF SIZE

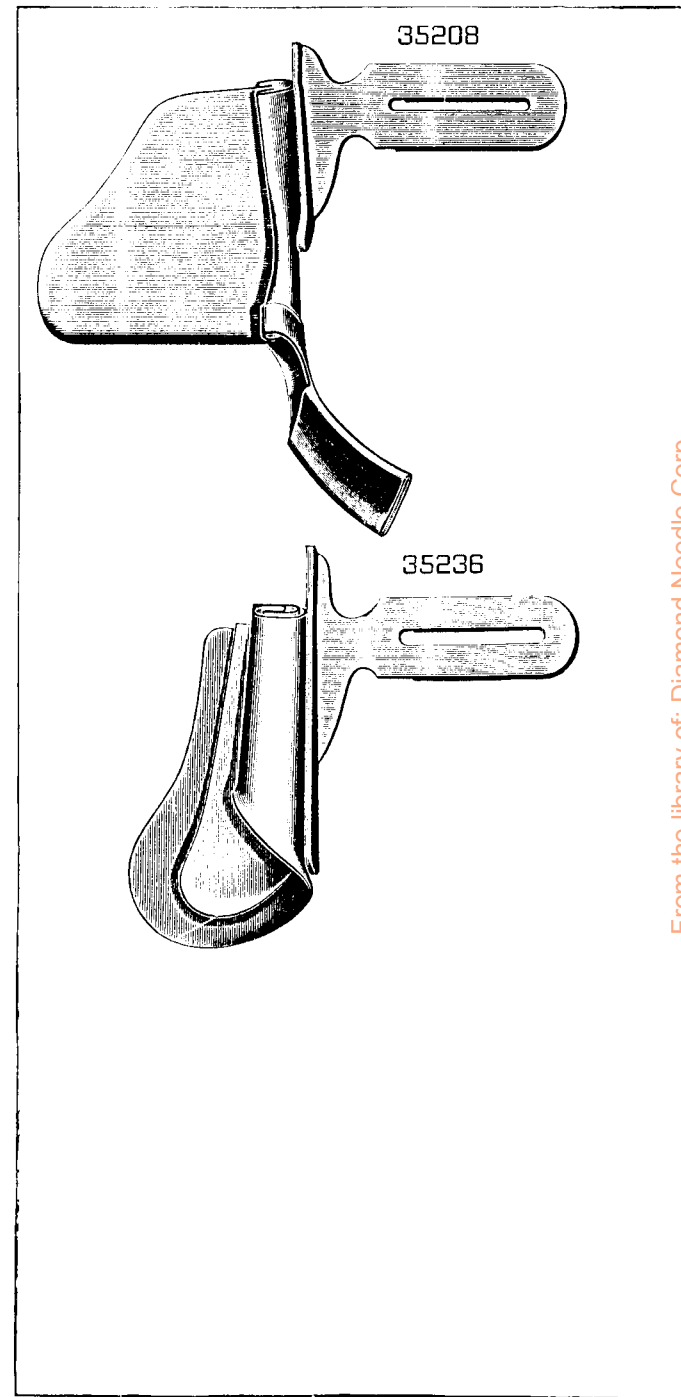


PLATE 2833--ONE-HALF SIZE

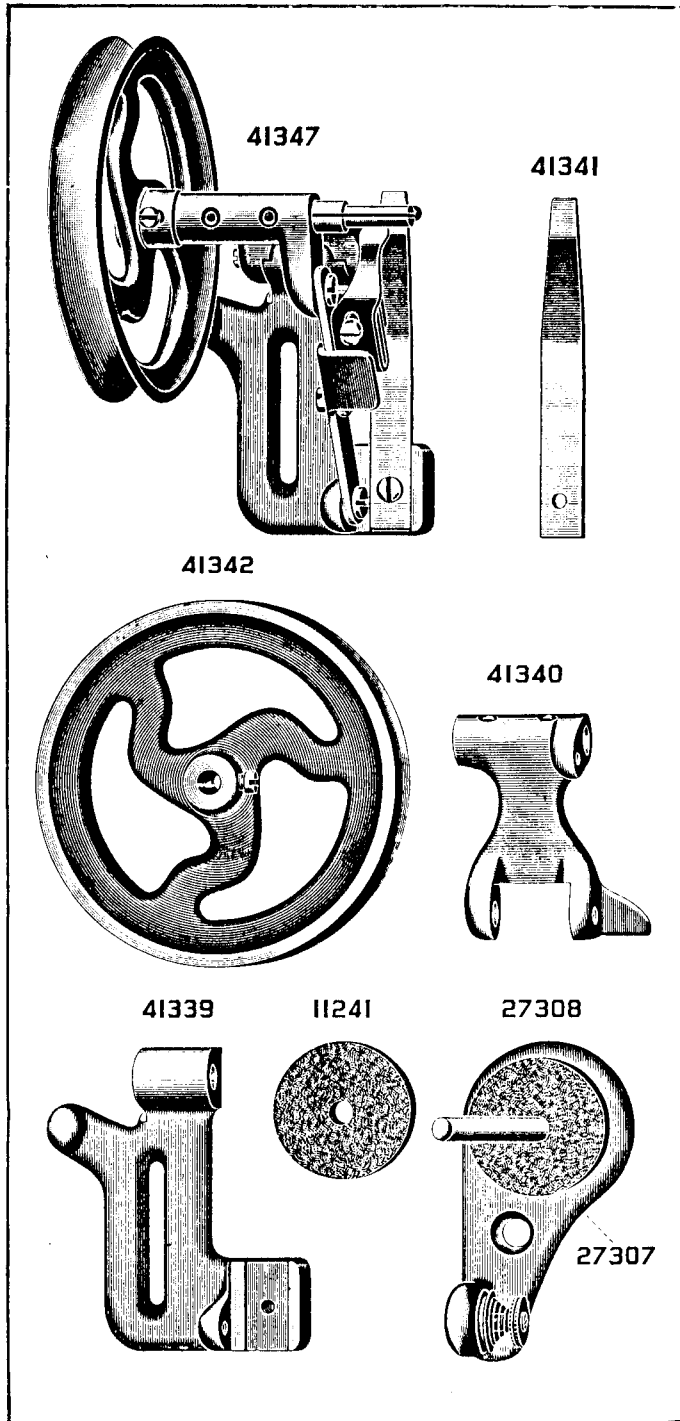
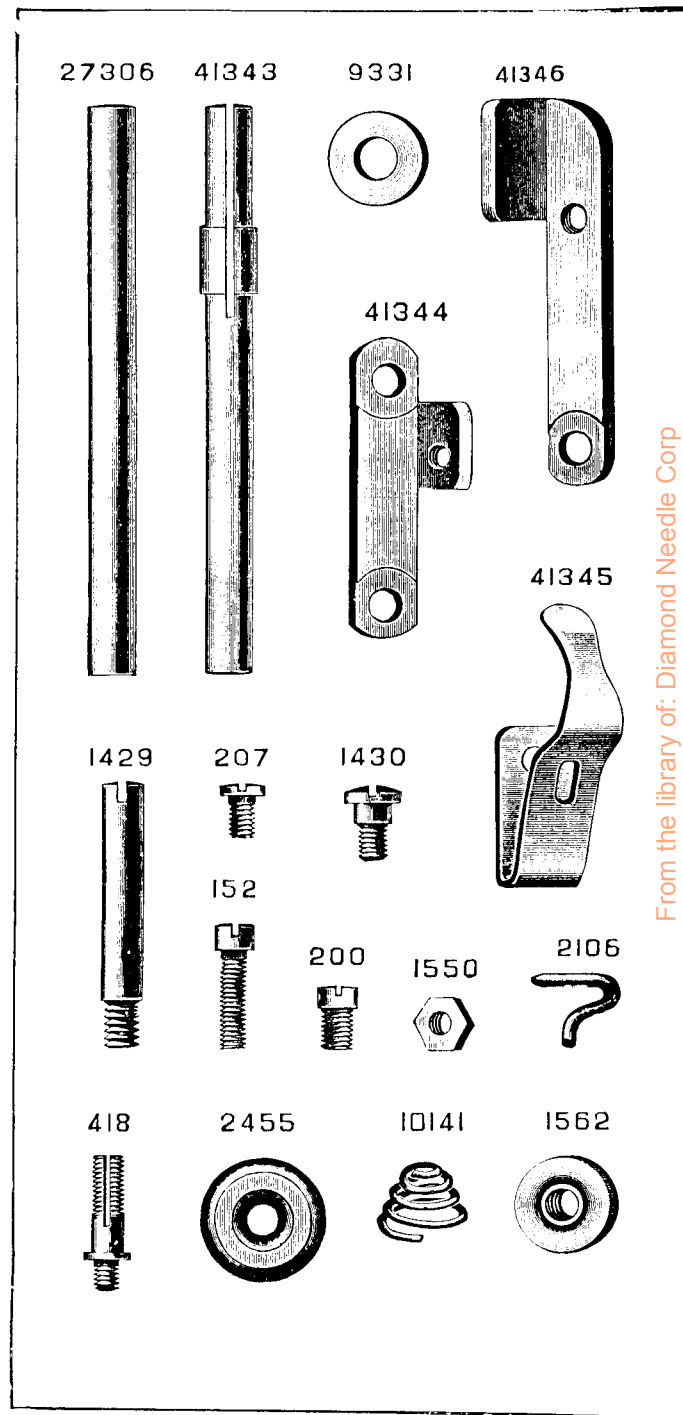


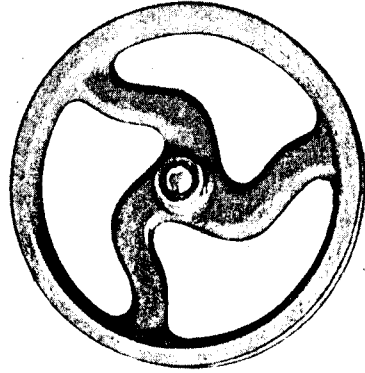
PLATE 2834--FULL SIZE



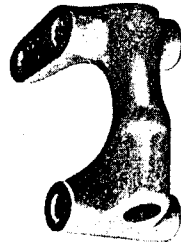
From the library of: Diamond Needle Corp

PLATE 3470—ONE-HALF SIZE

202473



225453

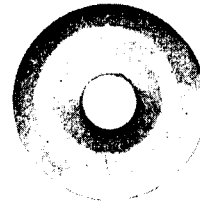


225381



PLATE 3471—FULL SIZE

2102



202407



201572



200082 202478 200299



225461

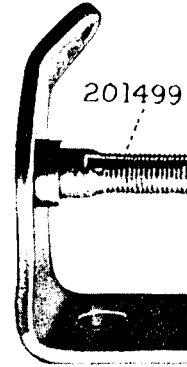
202104



225459



201499



225460



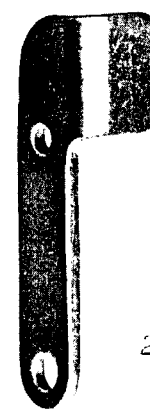
200056 200380



225455 225454



225458



225444



225456



202277 225438



From the library of: Diamond Needle Corp

PLATE 4761—FULL SIZE

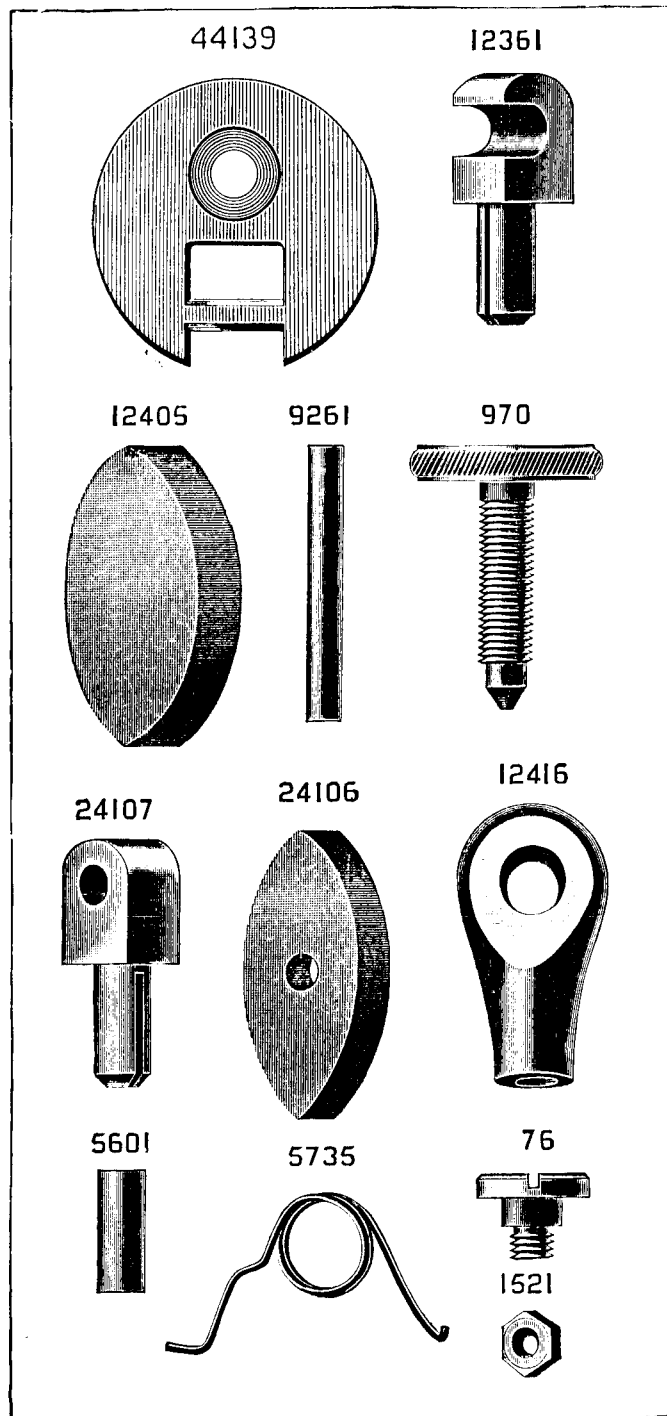
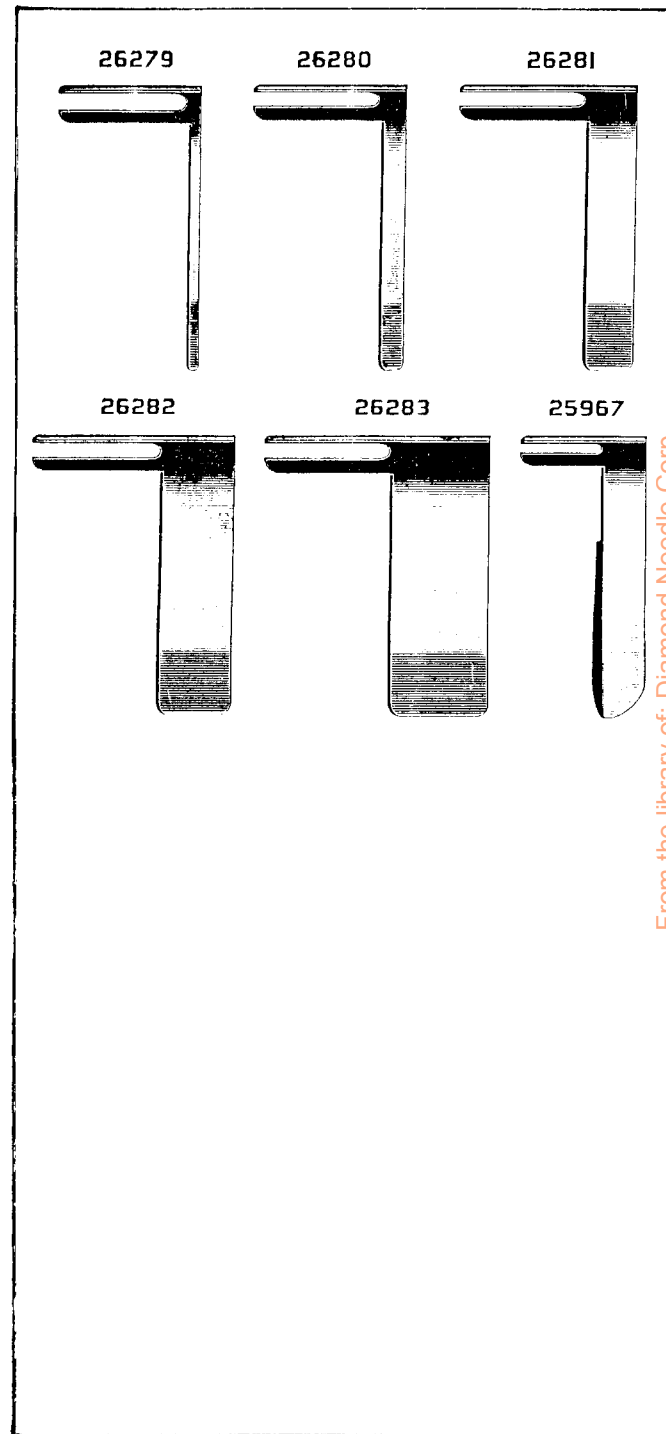


PLATE 5089—FULL SIZE



From the library of: Diamond Needle Corp

PLATE 5850—ONE-HALF SIZE

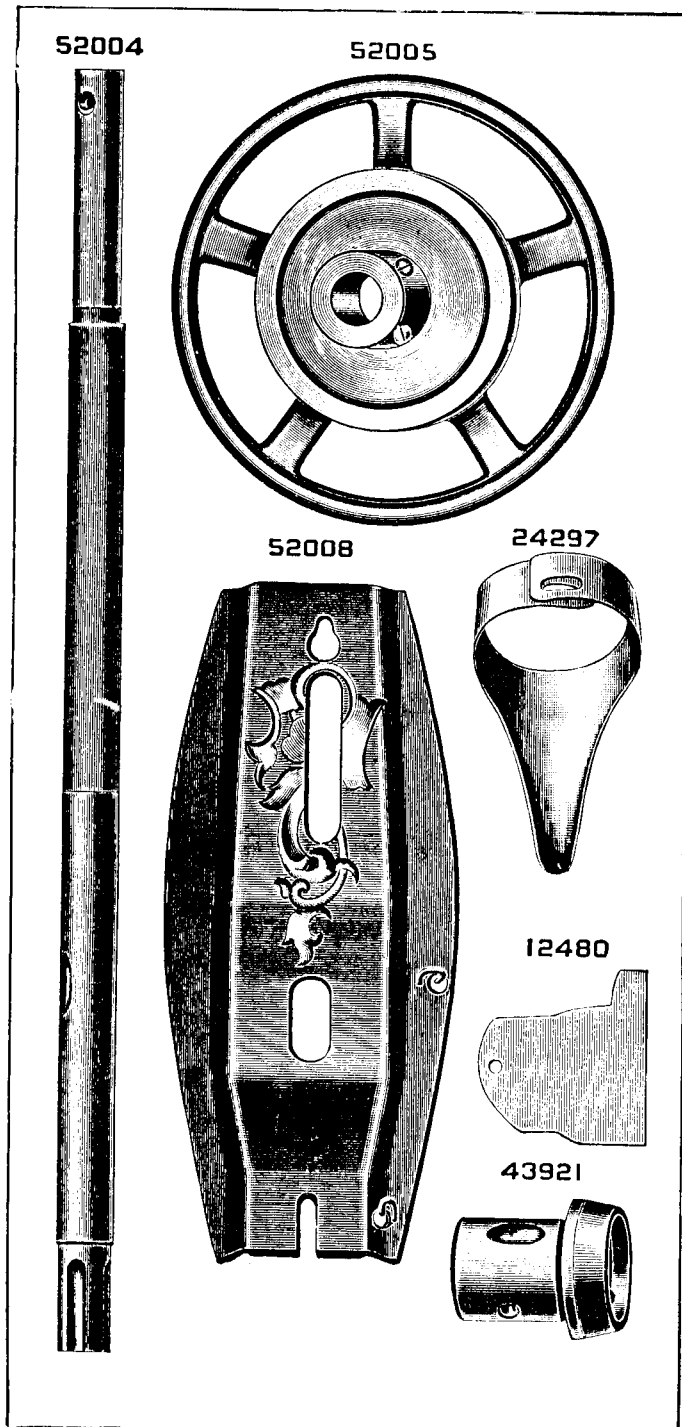
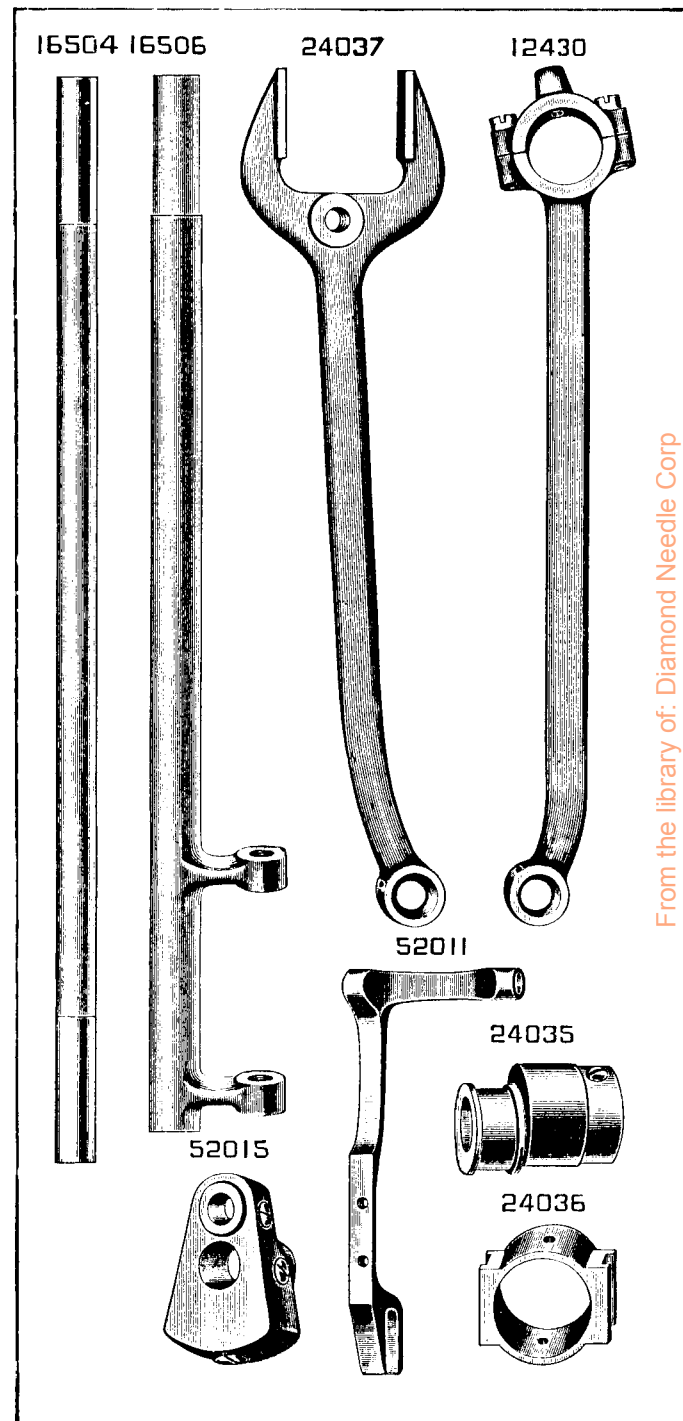


PLATE 5851—ONE-HALF SIZE



From the library of: Diamond Needle Corp

PLATE 5852—FULL SIZE

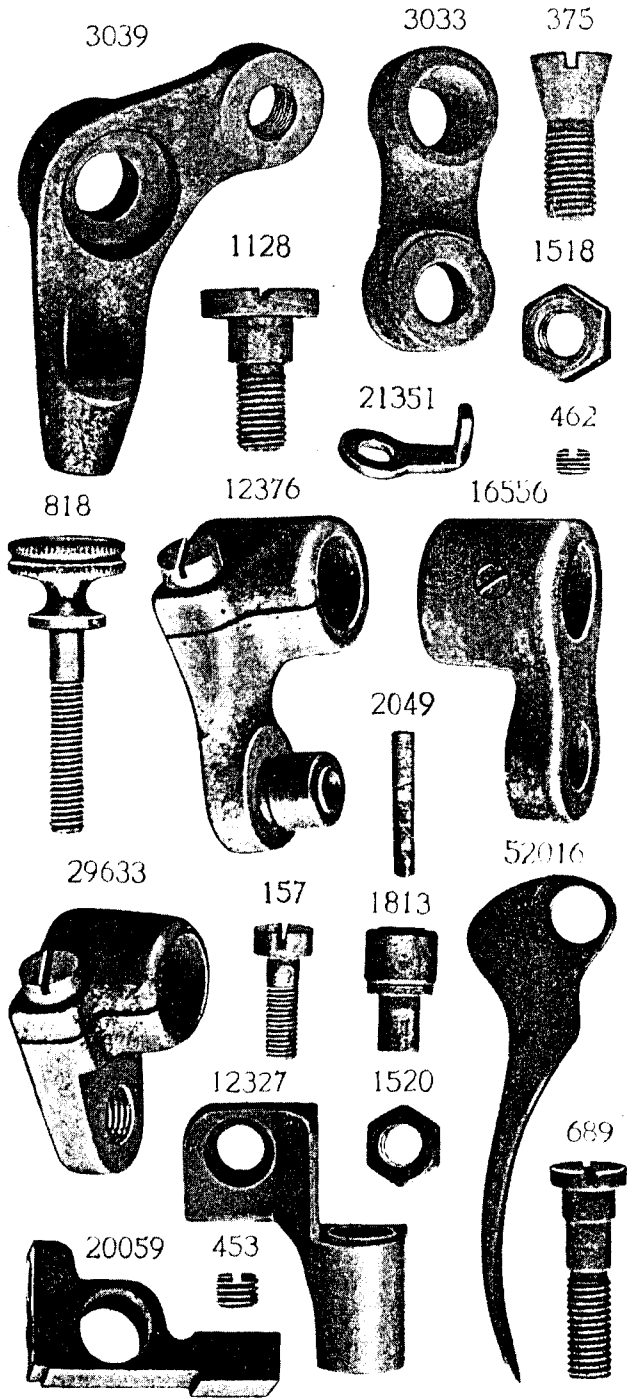
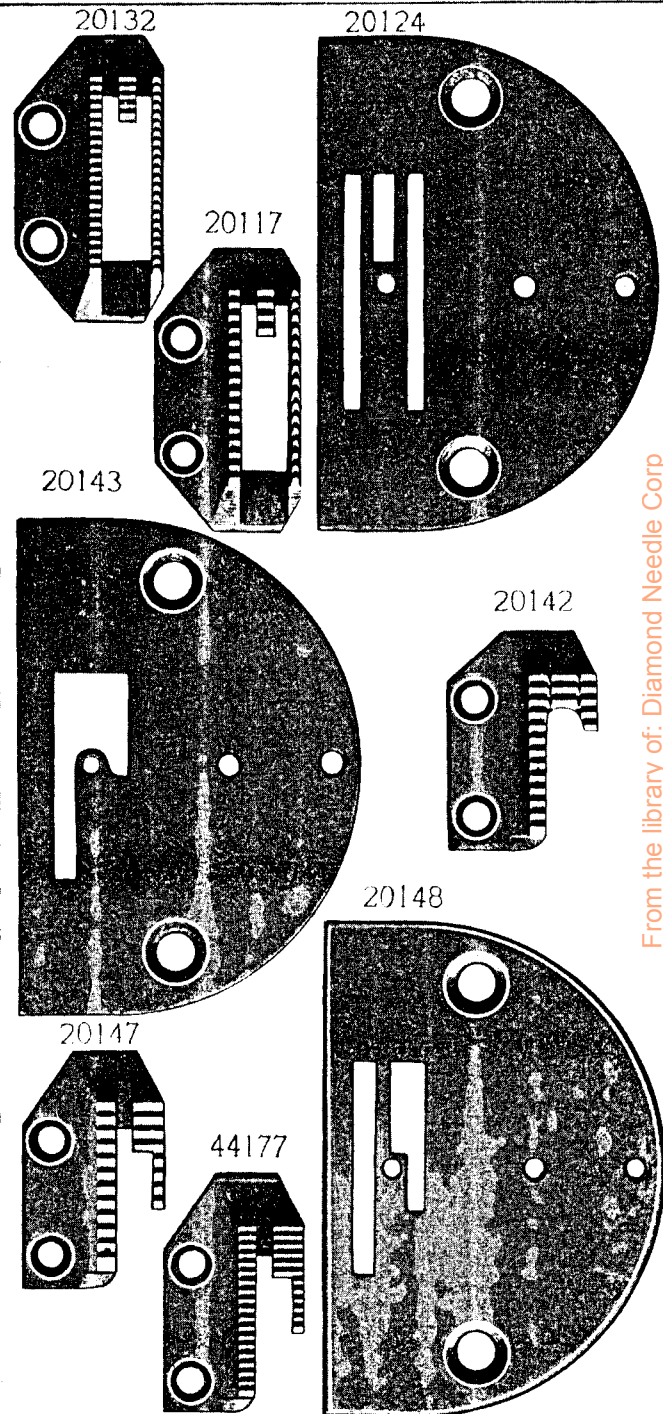


PLATE 5853—FULL SIZE



From the library of: Diamond Needle Corp

PLATE 5854—FULL SIZE

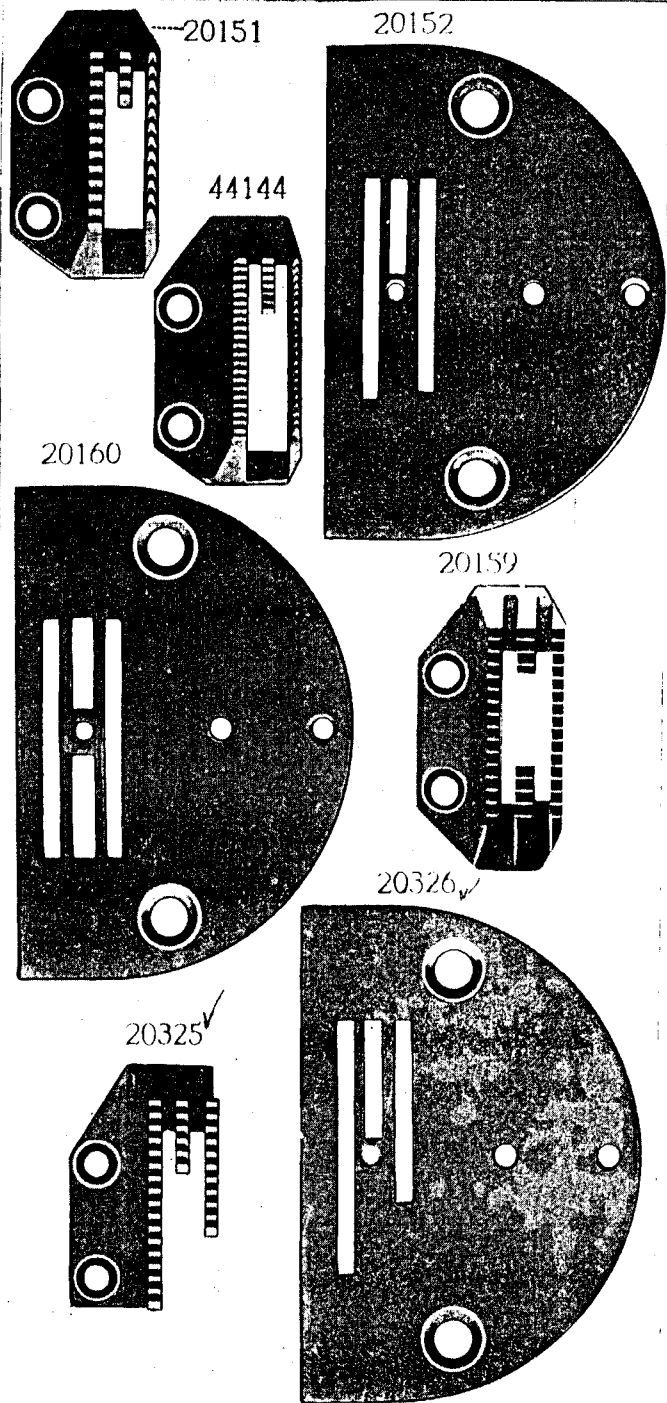


PLATE 5855—FULL SIZE

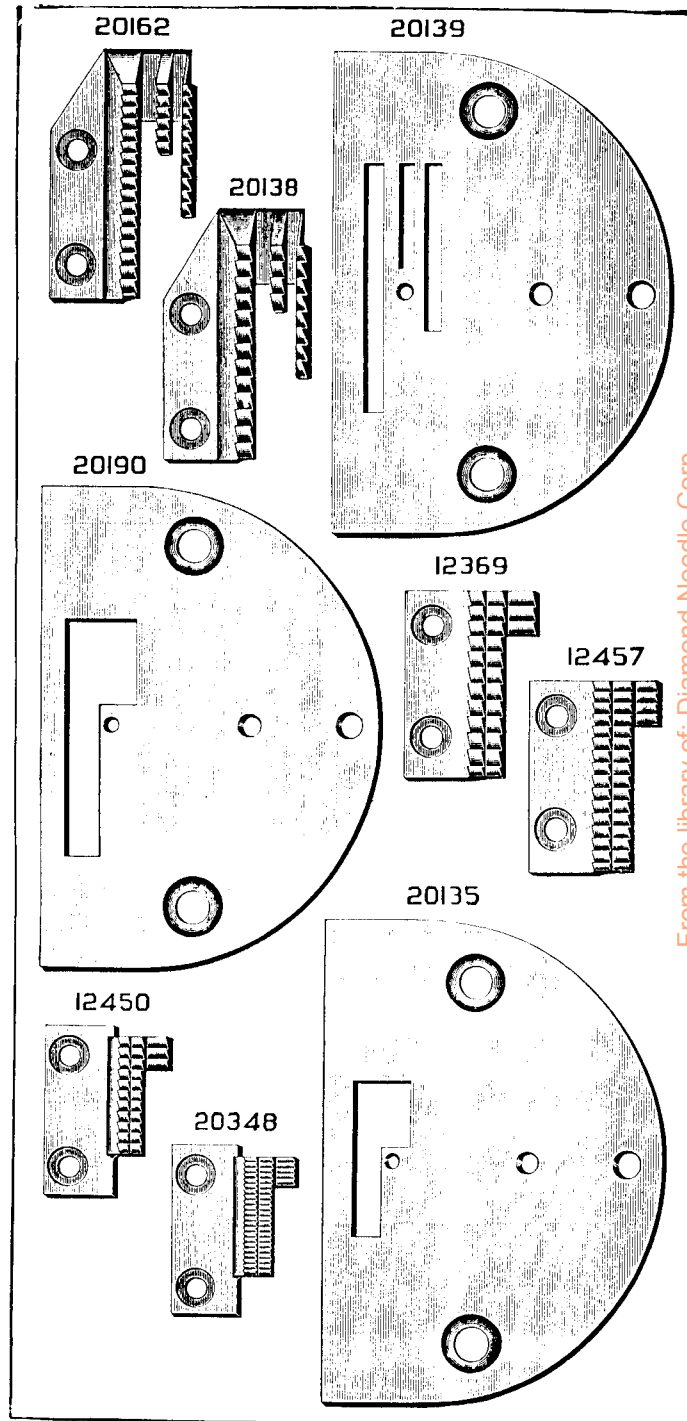


PLATE 5856—FULL SIZE

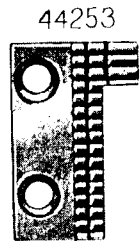
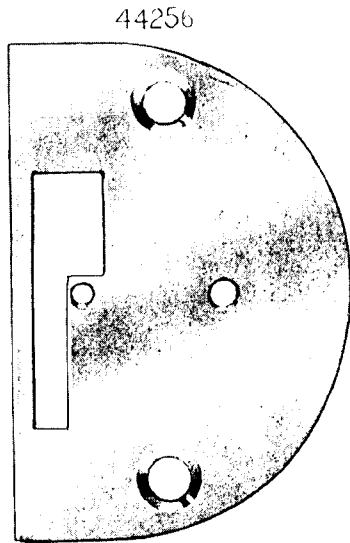
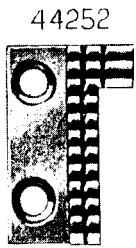
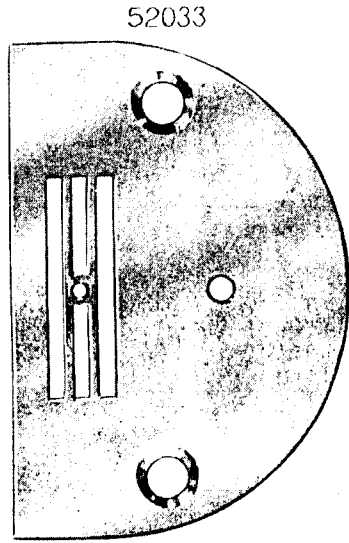
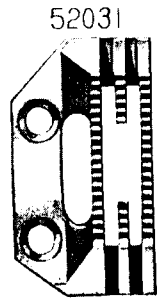
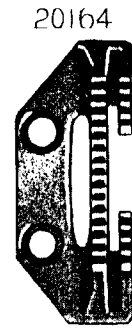
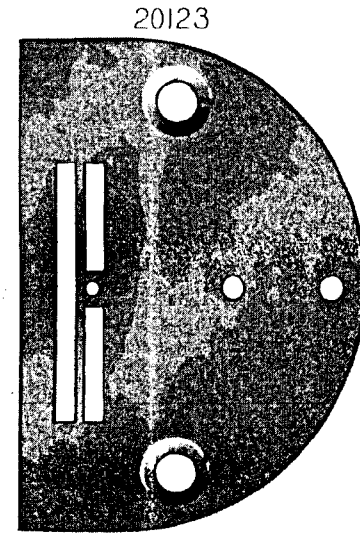
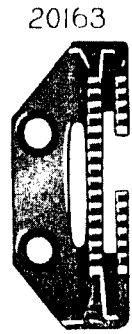


PLATE 5857—FULL SIZE



52131



52132

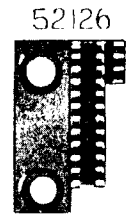
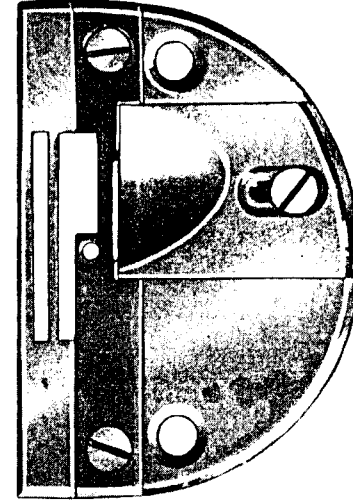


PLATE 5861—FULL SIZE

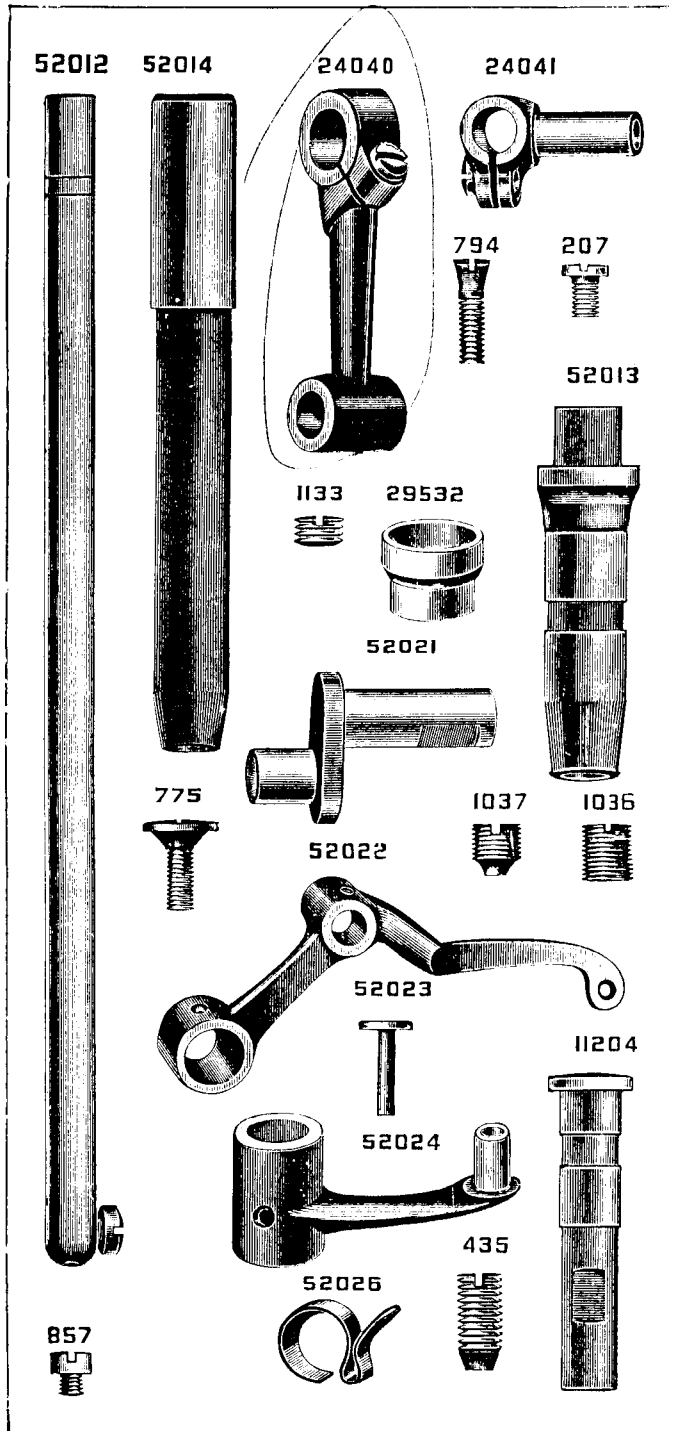
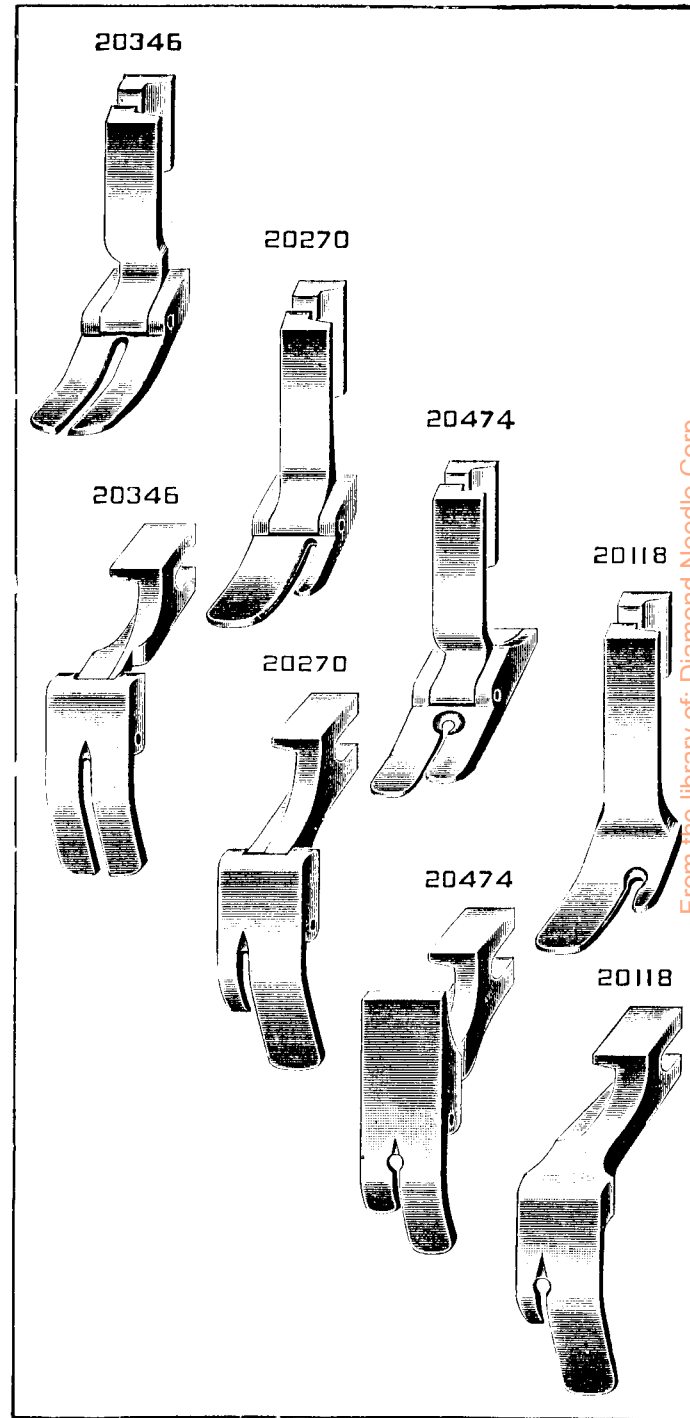


PLATE 5862—FULL SIZE



From the library of: Diamond Needle Corp.

PLATE 5864—FULL SIZE

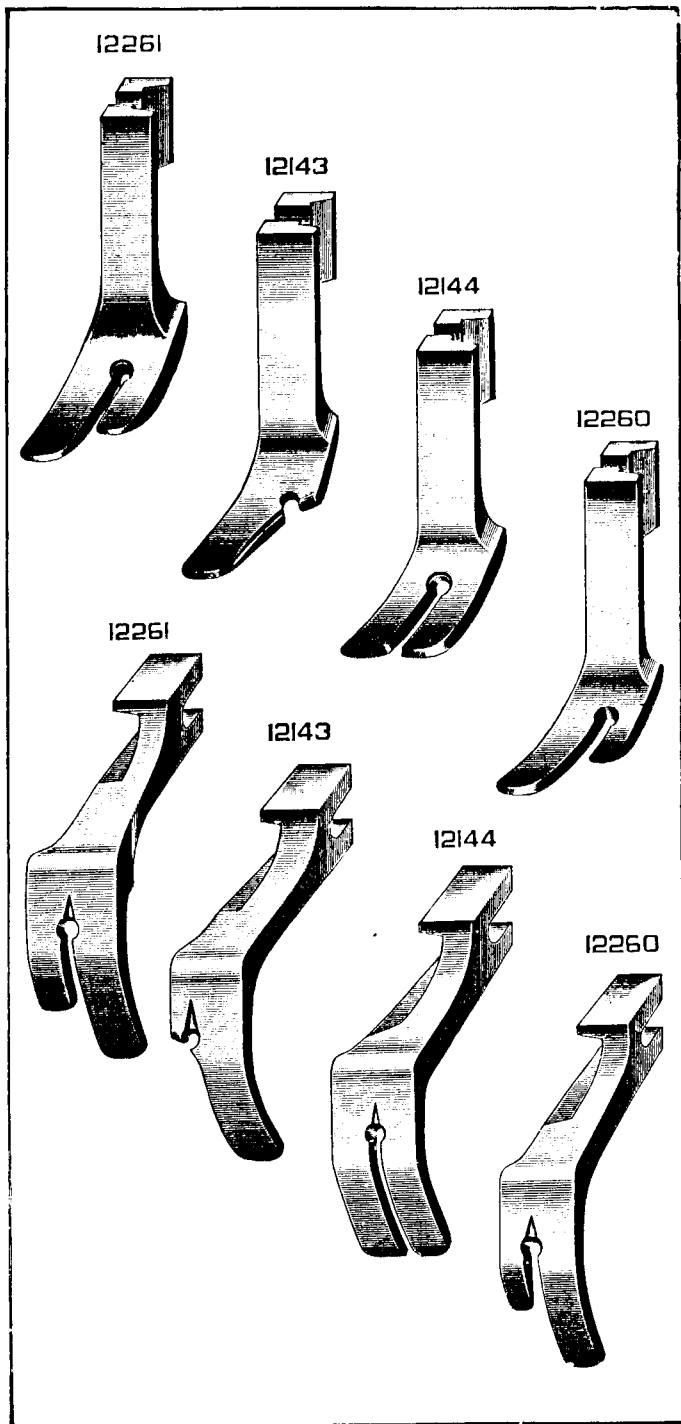
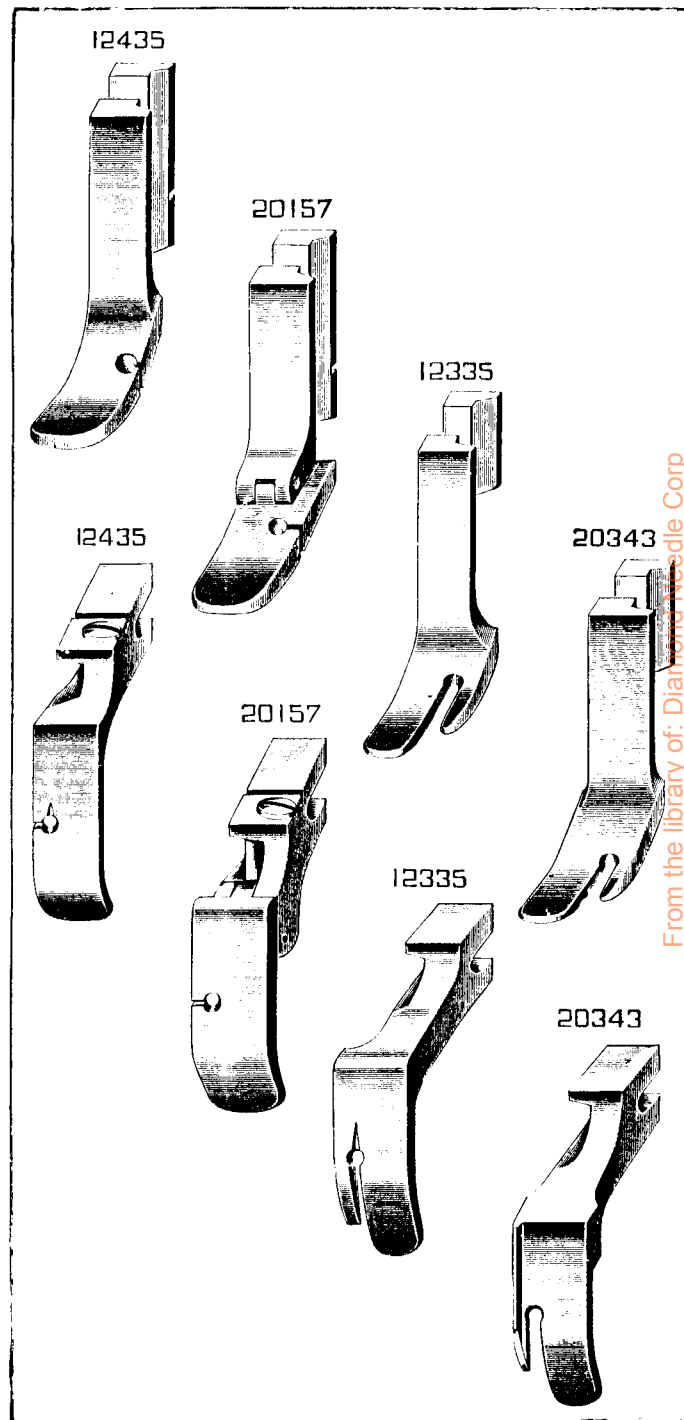


PLATE 5865—FULL SIZE



From the library of: Diamond Needle Corp

PLATE 5866—FULL SIZE

12462



12463



20134



20361



12462



12463



20134

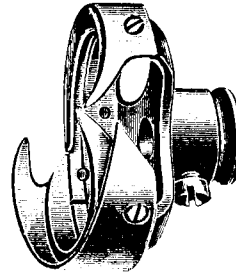


20361

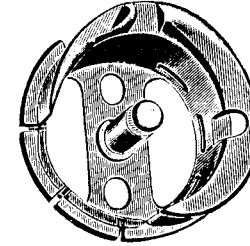


PLATE 5869—FULL SIZE

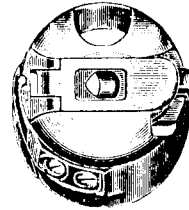
52076



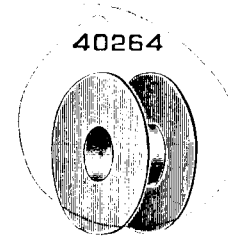
40396



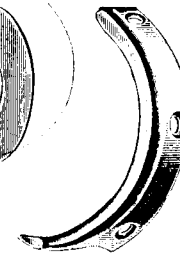
40395



40264



40274



40392



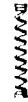
40409



2974



2975



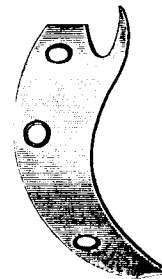
592



1367



40398



1053



40394



591



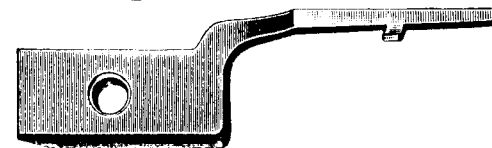
1380



1253



52018



704



From the library of: Diamond Needle Corp

PLATE 5870—ONE-HALF SIZE

52019 12391 11187 52037

40258

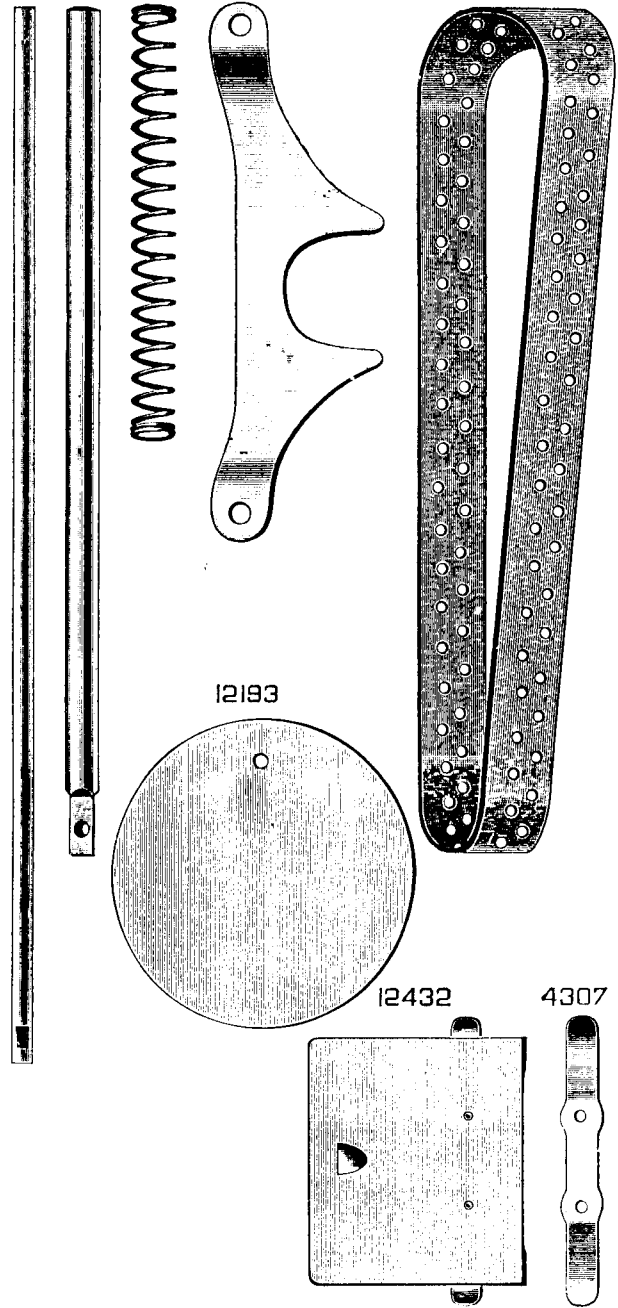
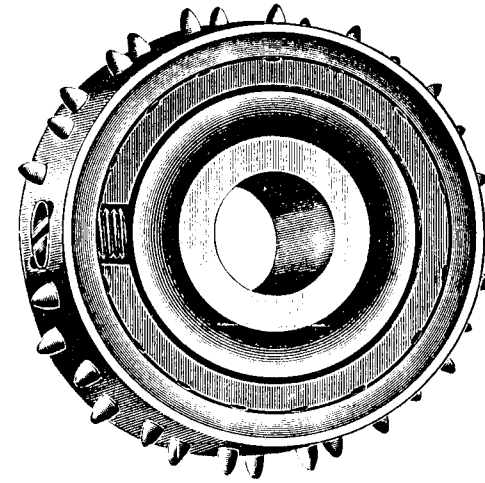


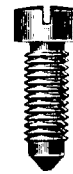
PLATE 5871—FULL SIZE

52017



40261

1362



1148



447



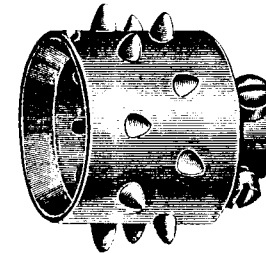
50143



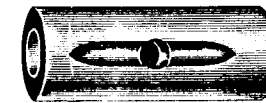
40263



52045



52020



40276



52039



52044



From the library of: Diamond Needle Corp

PLATE 5872—FULL SIZE

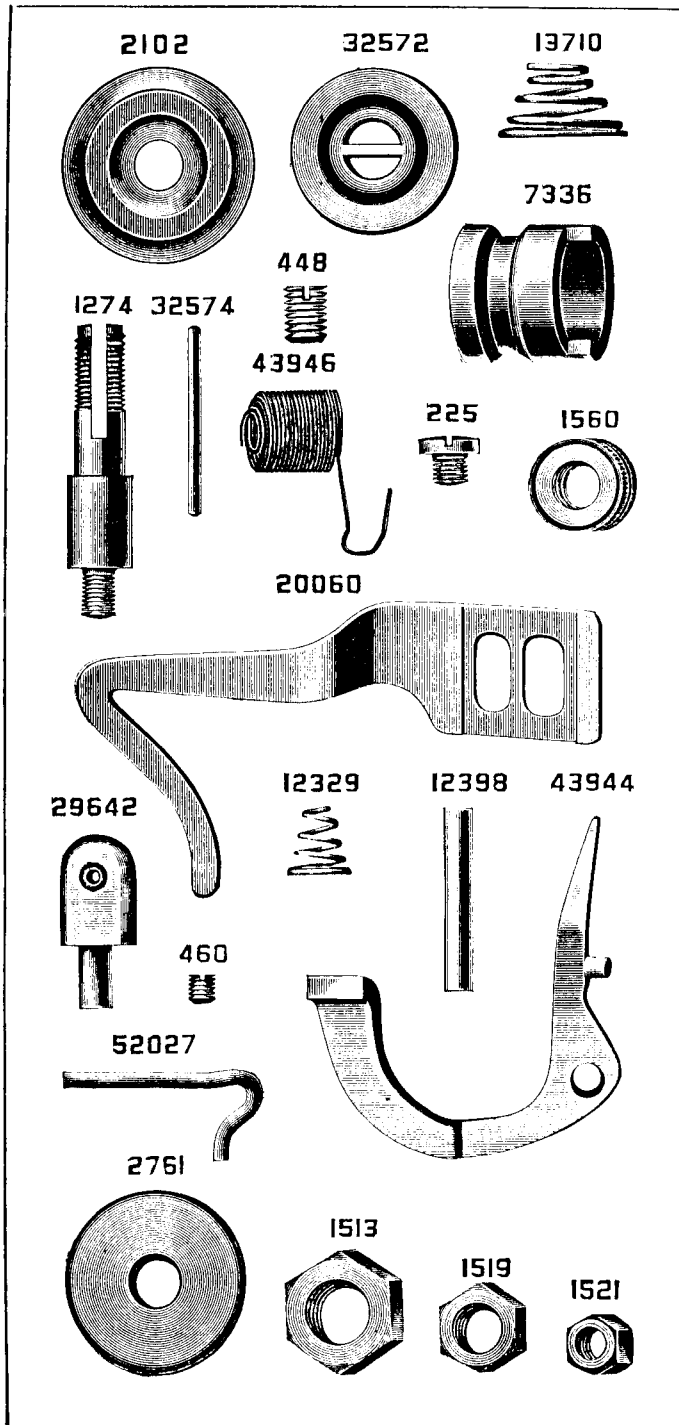
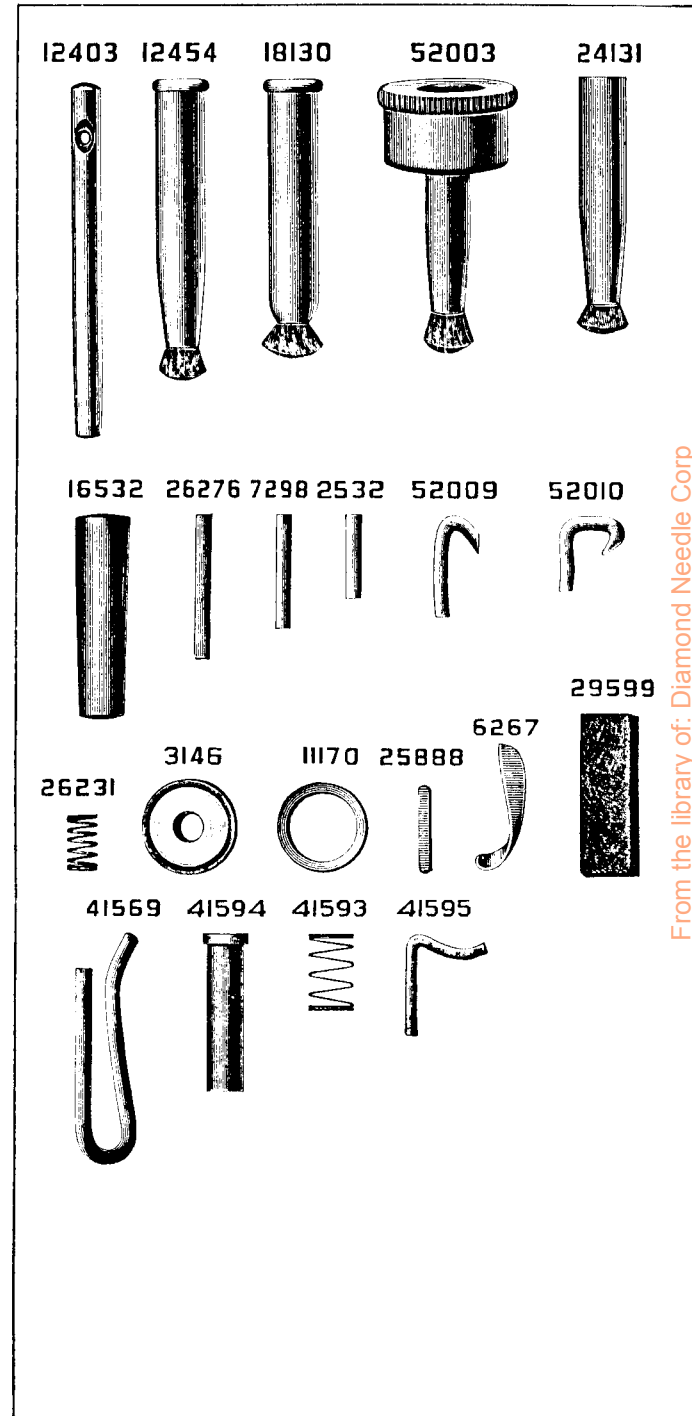


PLATE 5873—FULL SIZE



From the library of: Diamond Needle Corp

PLATE 5875—FULL SIZE

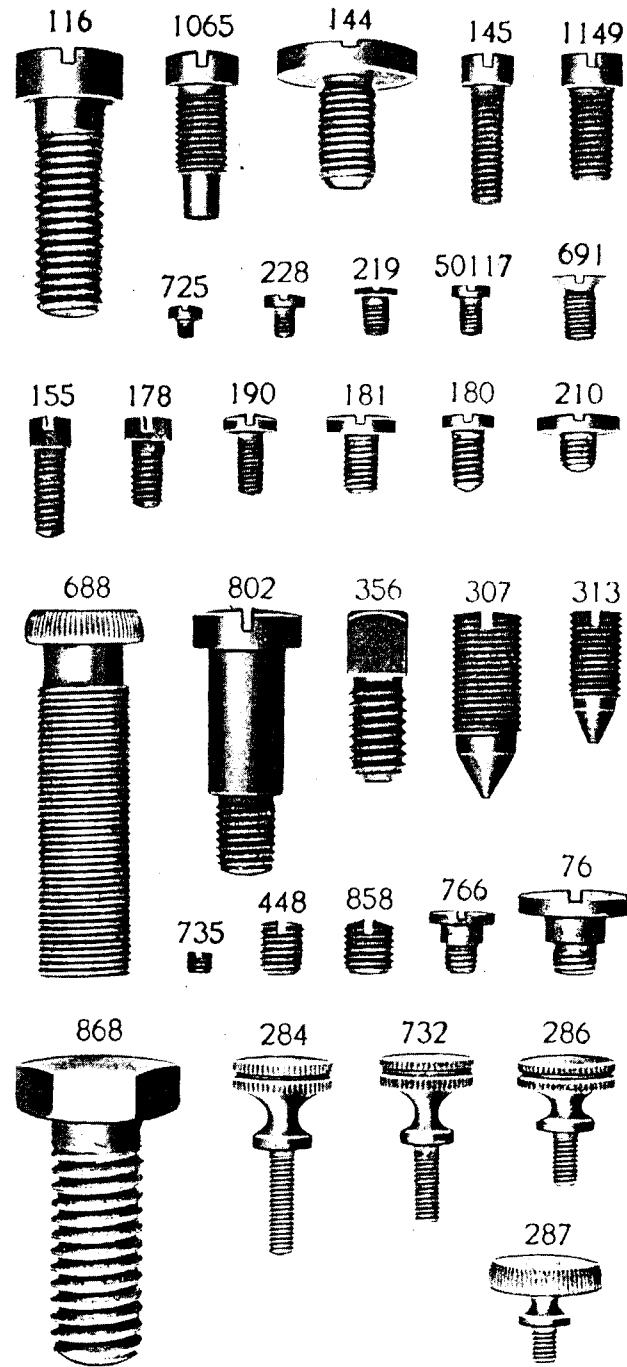
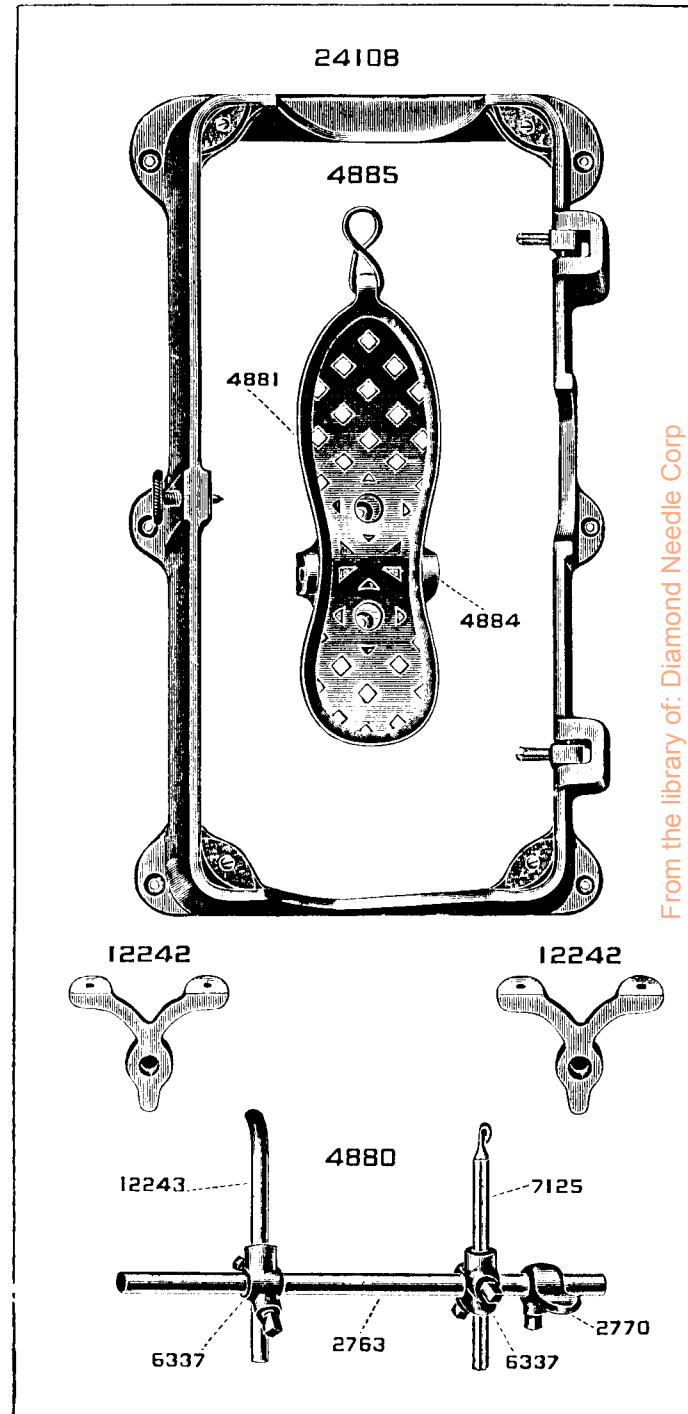


PLATE 5876—ONE-FOURTH SIZE



From the library of: Diamond Needle Corp

PLATE 5877—ONE-FOURTH SIZE

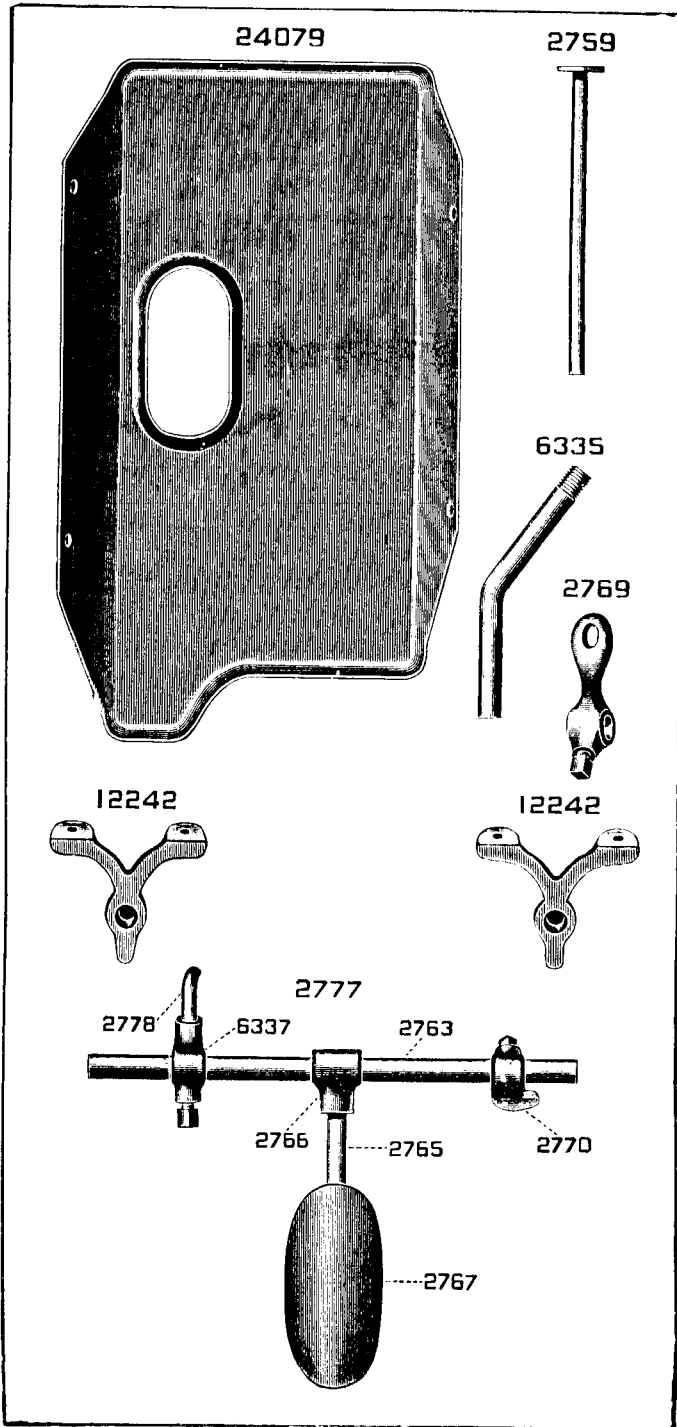
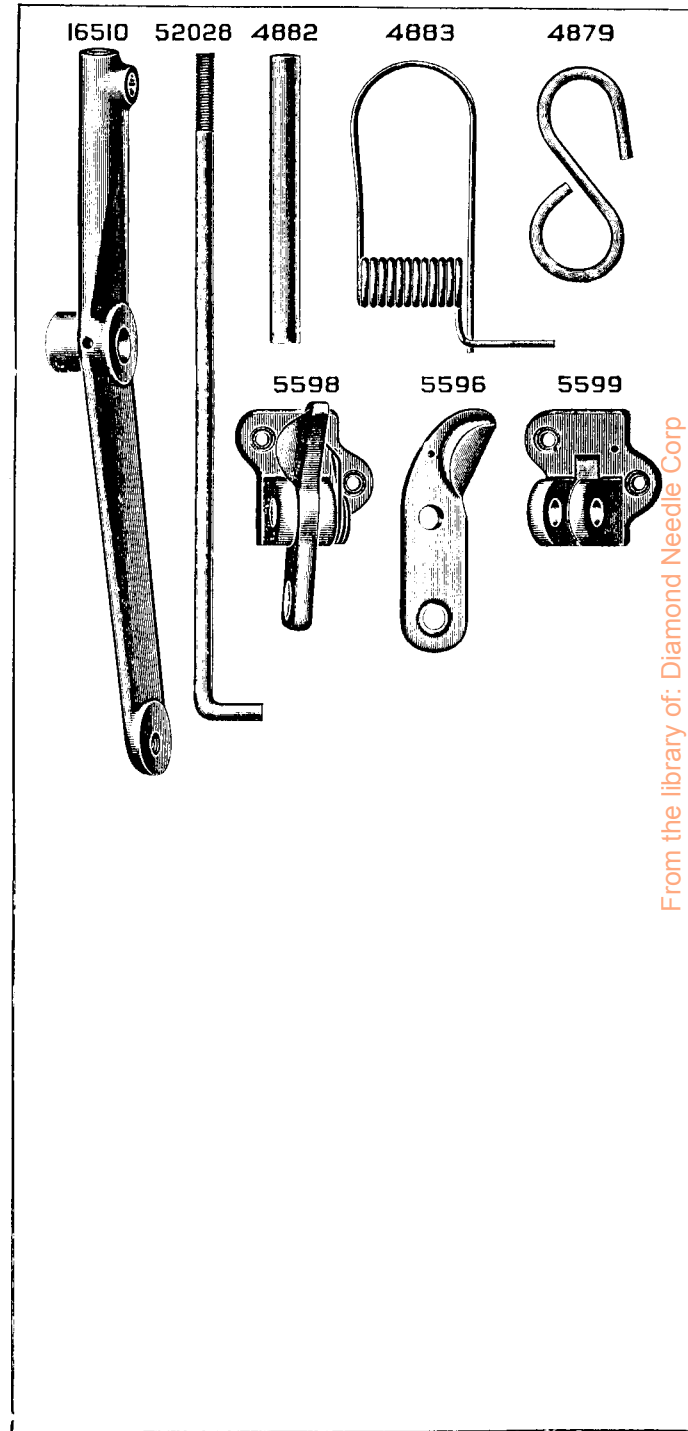
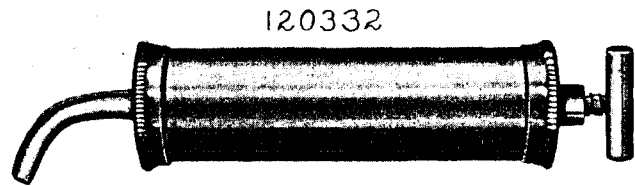


PLATE 5878—ONE-HALF SIZE

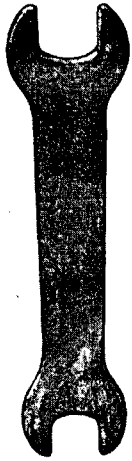


From the library of: Diamond Needle Corp

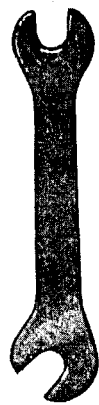
PLATE 5879—ONE-HALF SIZE



8909



8908



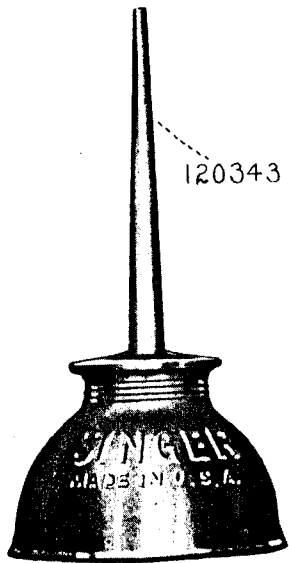
26026



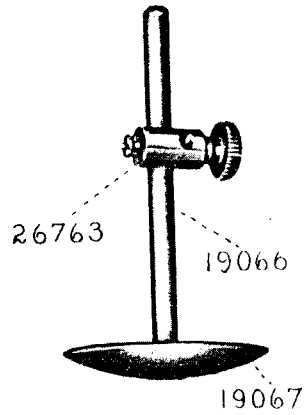
26485



120342



120343



26763

19066

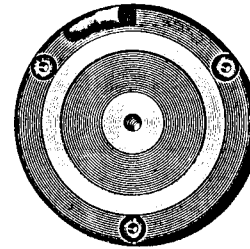
19067

PLATE 5883—ONE-FOURTH SIZE

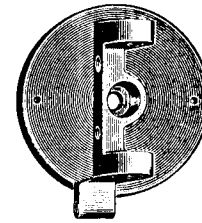
35517



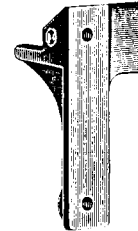
35518



36392



36389



35525

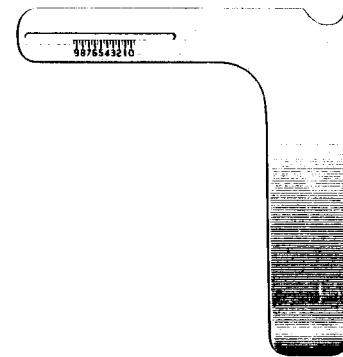


PLATE 5884—ONE-HALF SIZE

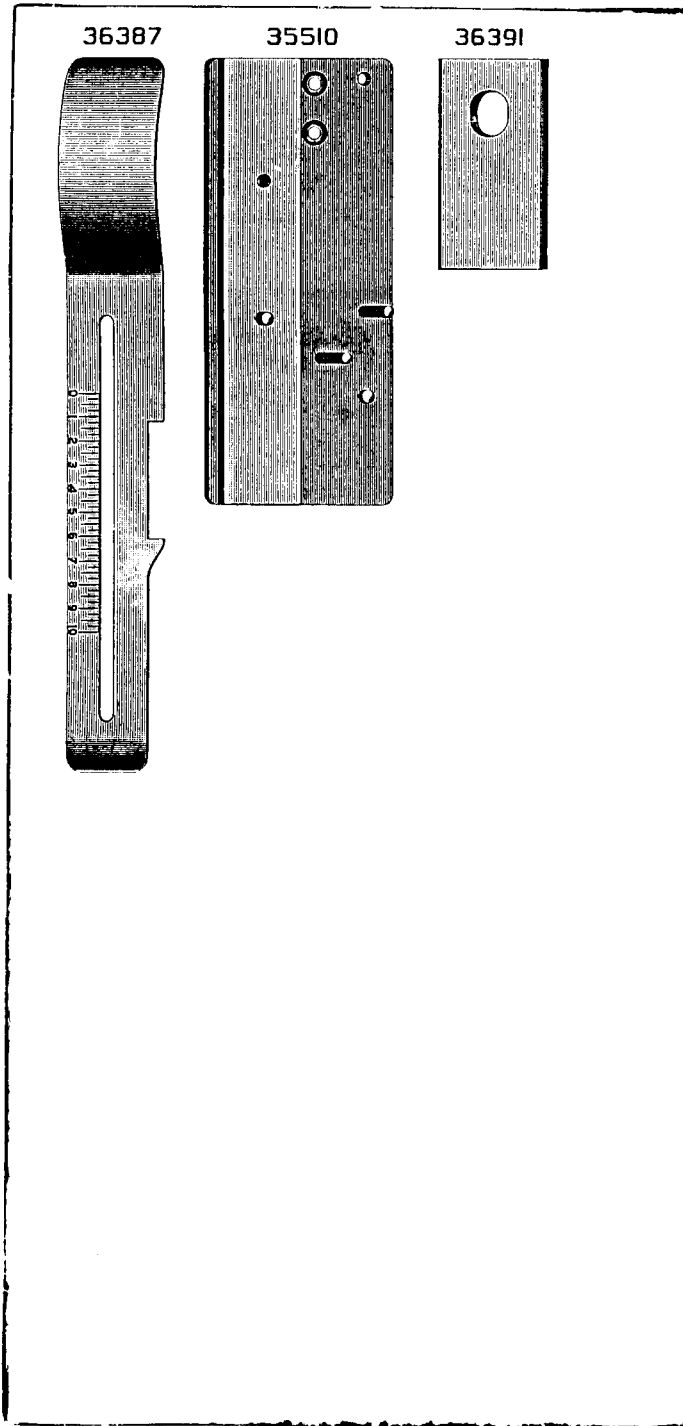


PLATE 5885—FULL SIZE

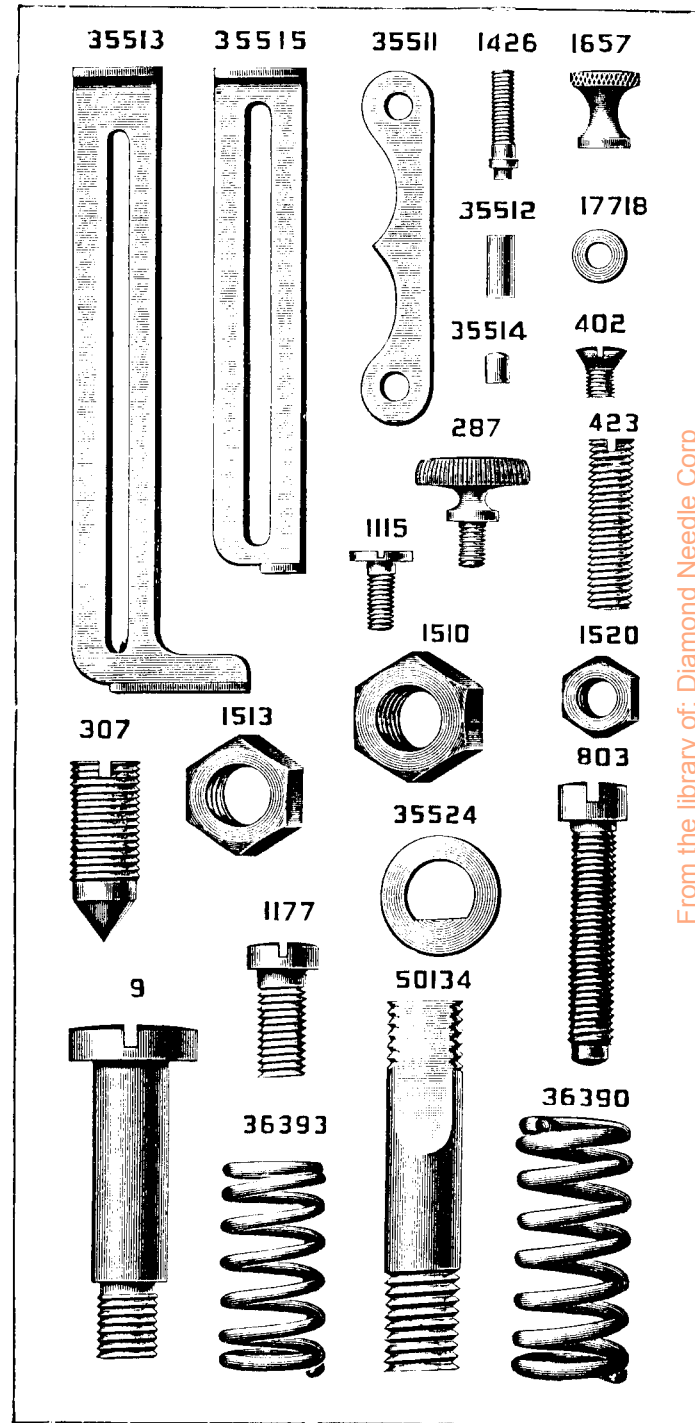


PLATE 5886—FULL SIZE

35528



40322



35528



40322



36654



36654



40315

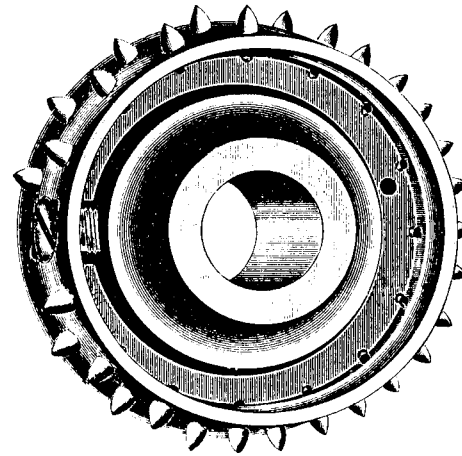


40315

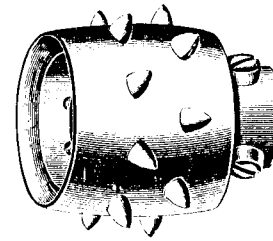


PLATE 5887—FULL SIZE

52041



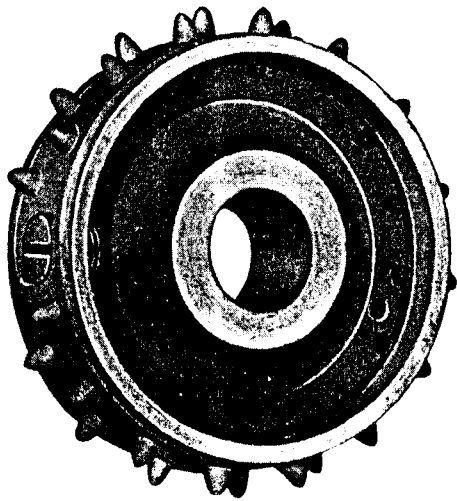
52040



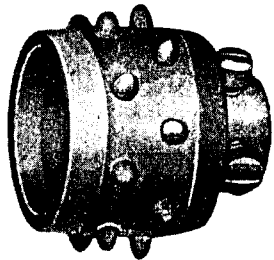
From the library of: Diamond Needle Corp

PLATE 5888—FULL SIZE

52050



52048



52049



PLATE 5889—FULL SIZE

880



966



158



171



50145



590



1443



185



200079



389



1147



208



457



456



From the library of: Diamond Needle Corp

PLATE 5892—FULL SIZE

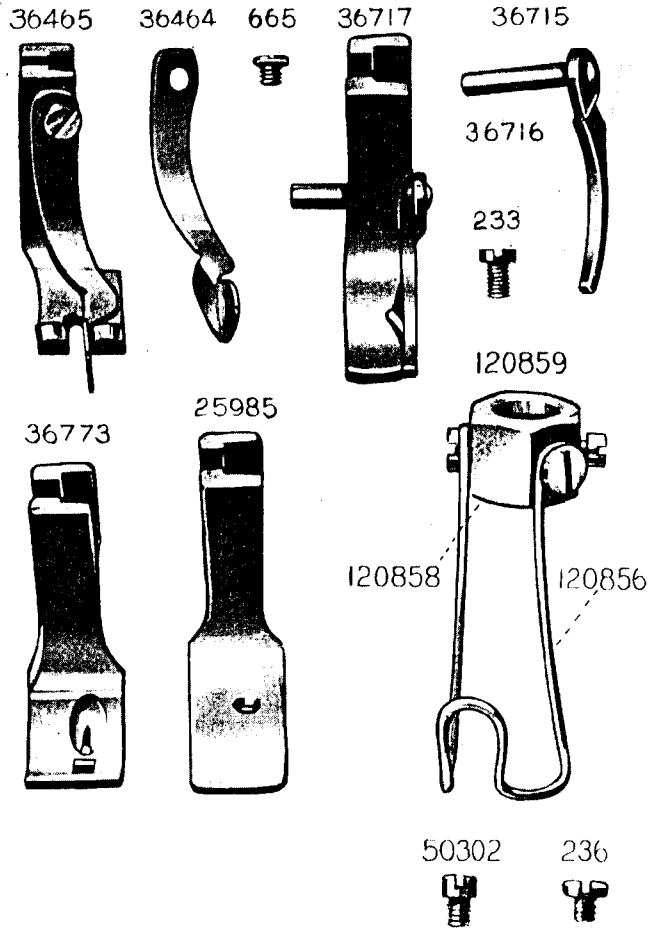
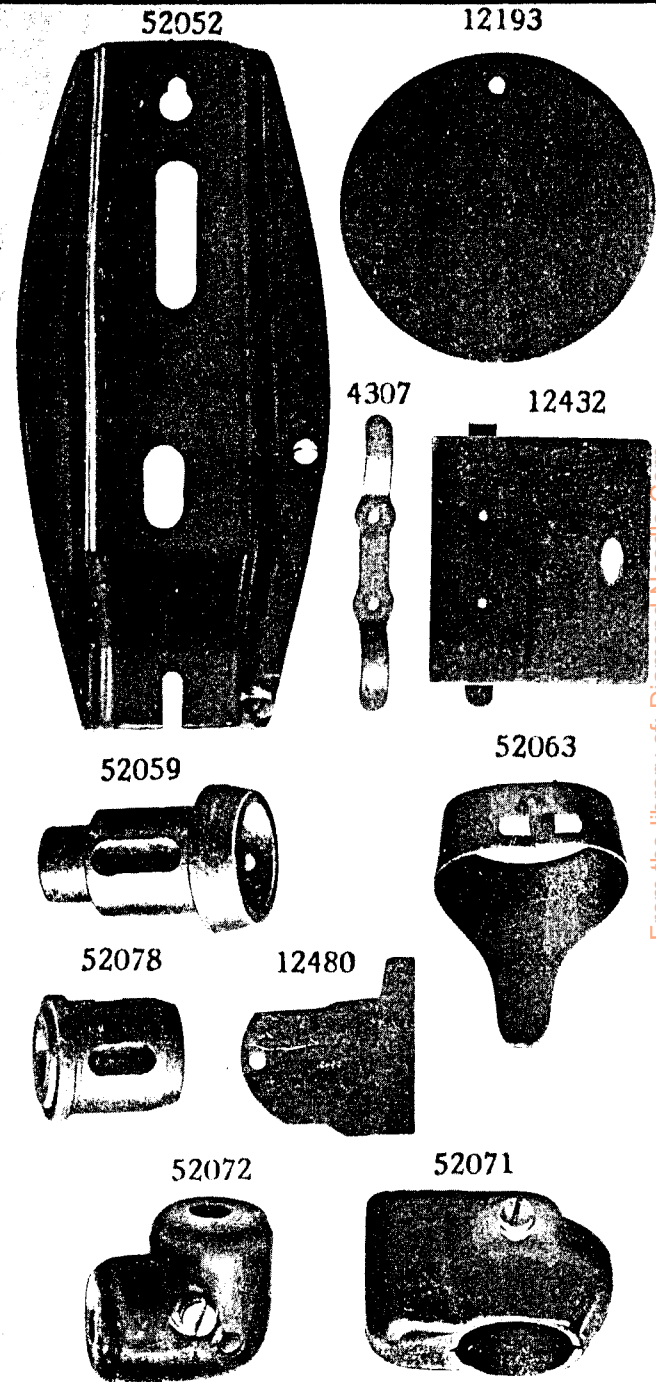


PLATE 5894—ONE-HALF SIZE



From the library of: Diamond Needle Corp

PLATE 5895—ONE-HALF SIZE

52058 52068 52065 52070 24037

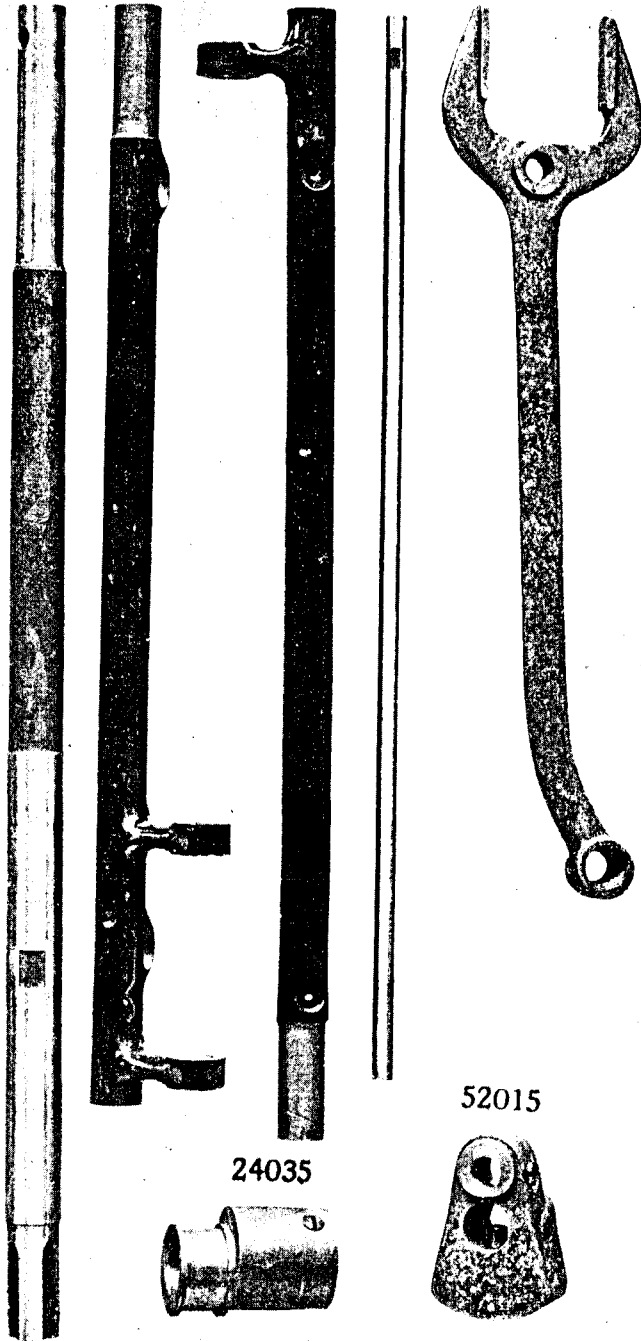
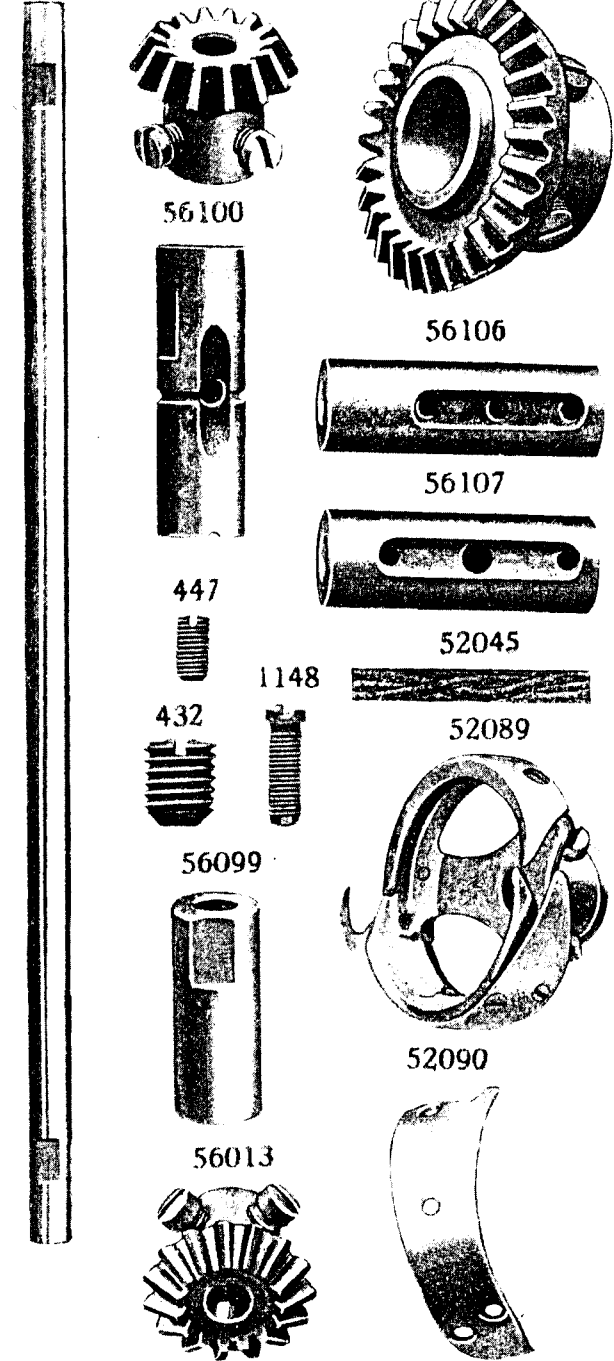


PLATE 5898—FULL SIZE

52062 56101 52060



From the library of: Diamond Needle Corp

PLATE 5902—ONE-HALF SIZE

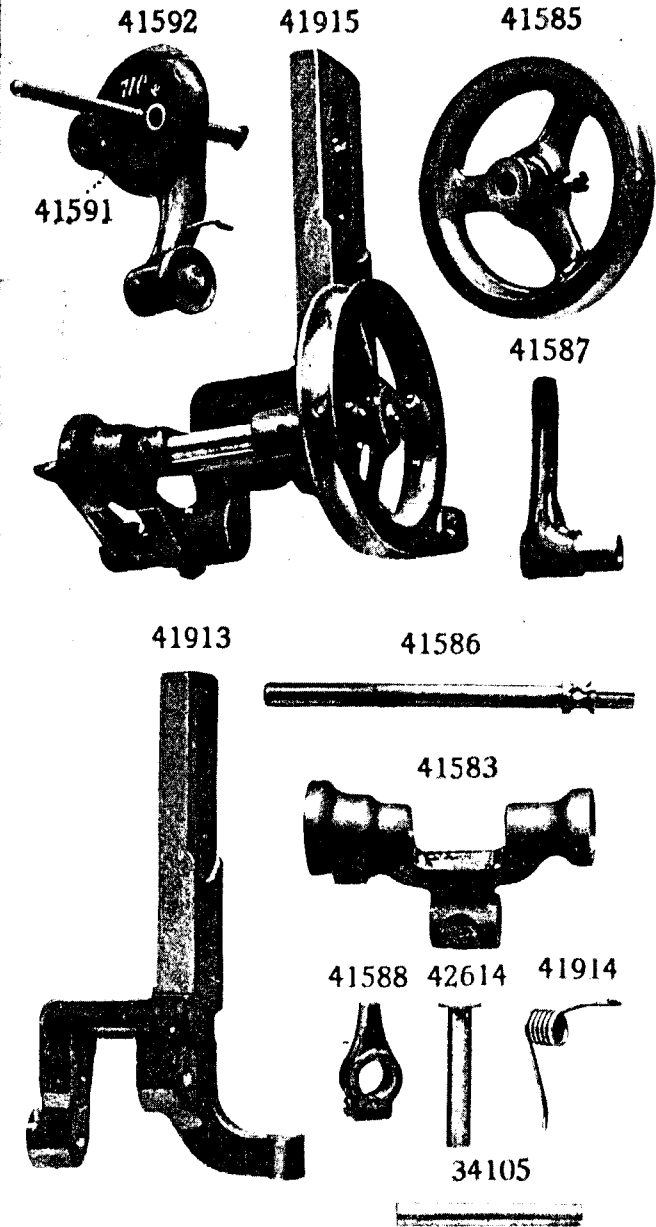
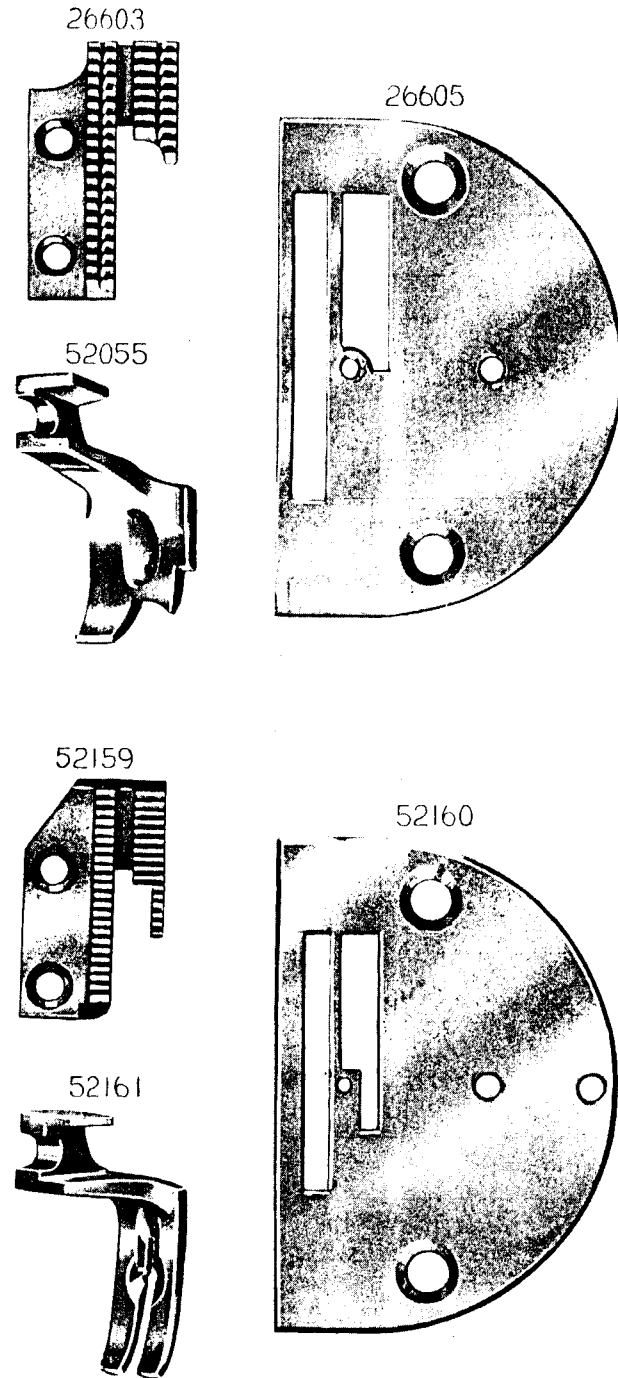


PLATE 5905—FULL SIZE



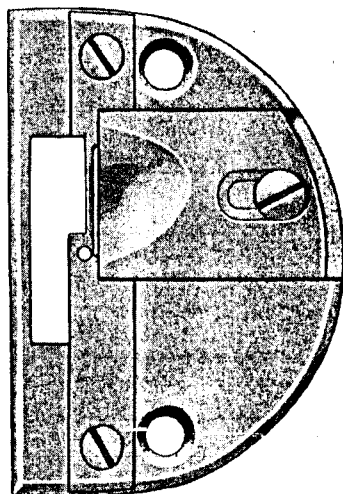
From the library of: Diamond Needle Corp

PLATE 5912—FULL SIZE

19103



5732



24573



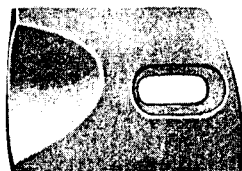
24722



5730



5731



578



236



691



19392

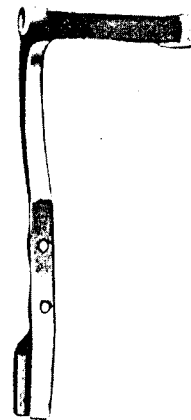


PLATE 5916—ONE-HALF SIZE

52141 52129



52452



126392



From the library of: Diamond Needle Corp

PLATE 5917—FULL SIZE

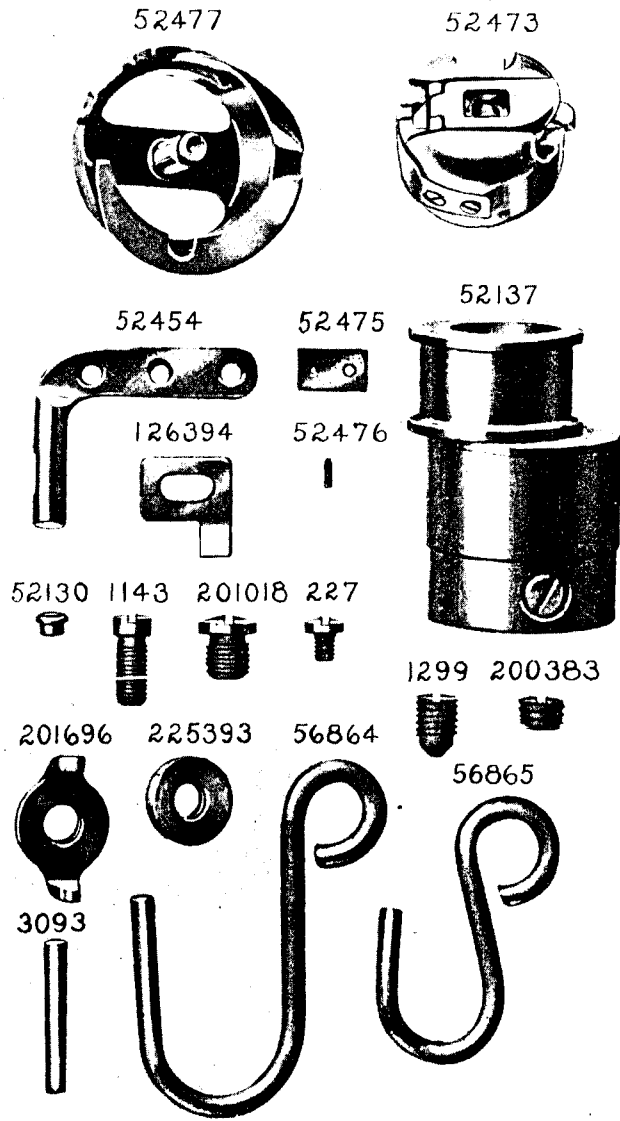


PLATE 5918—ONE-HALF SIZE

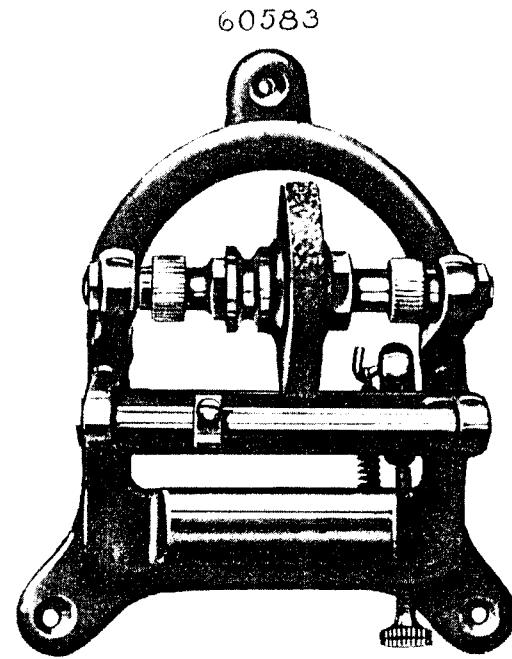
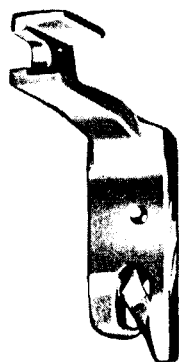
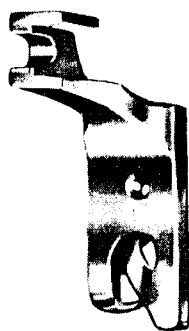


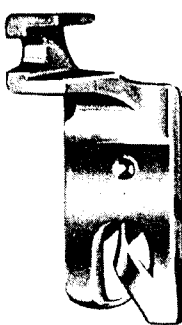
PLATE 5919—FULL SIZE



120803



120804



120805



120939



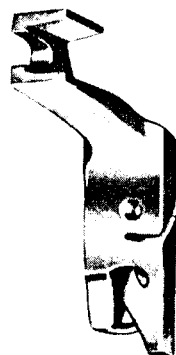
120838



120843



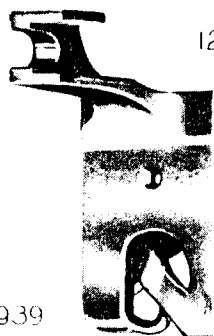
PLATE 5920—FULL SIZE



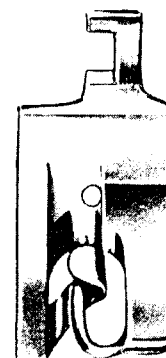
120837



120806



120807



120939



120838



120839



From the library of: Diamond Needle Corp

PLATE 5921—FULL SIZE

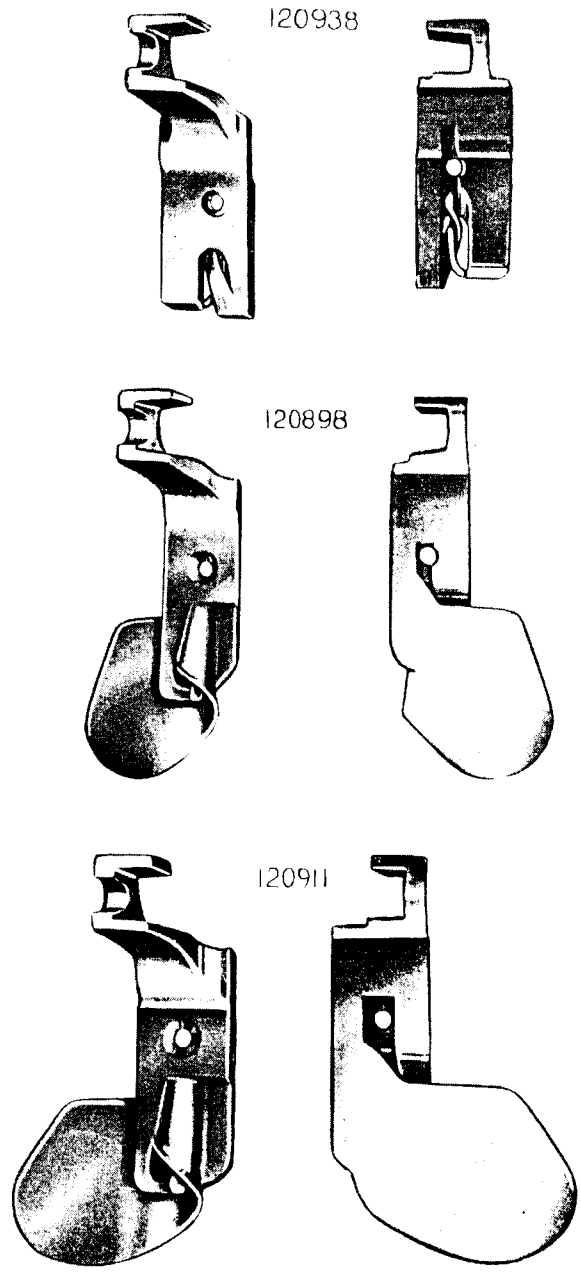
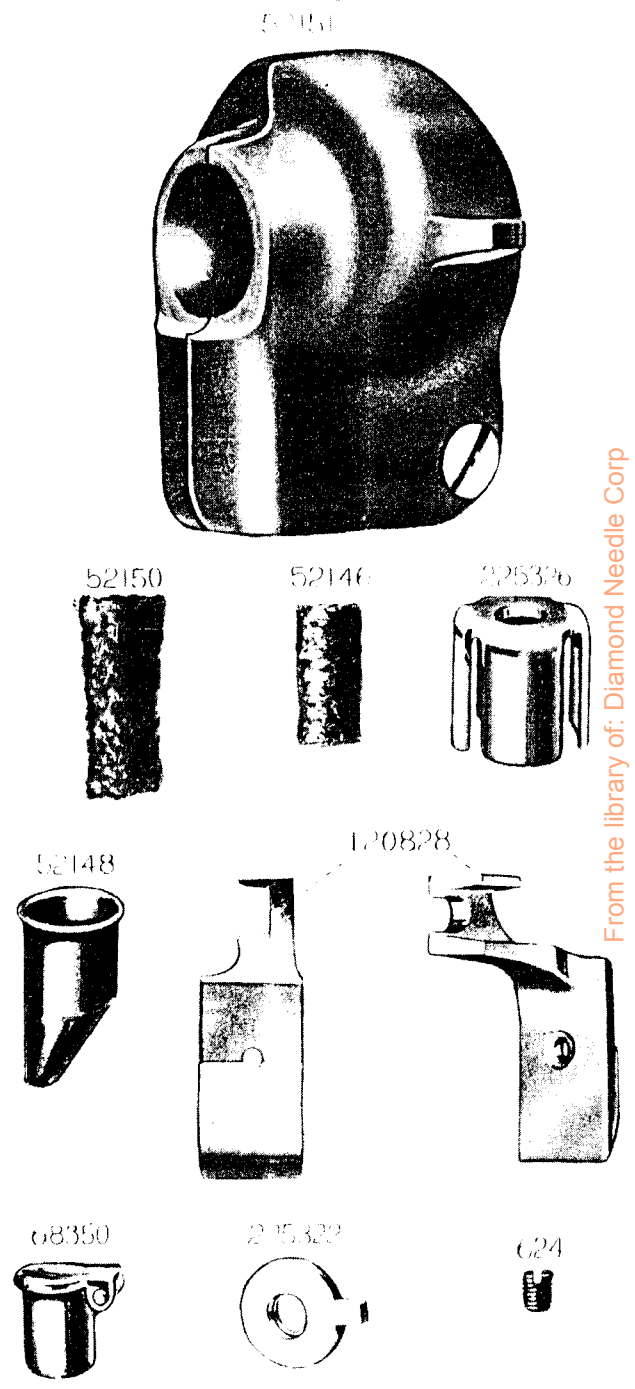


PLATE 5922—FULL SIZE



From the library of: Diamond Needle Corp

PLATE 5945 - FULL SIZE

36575



36574



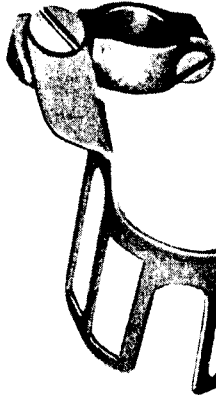
36576



50202



36821



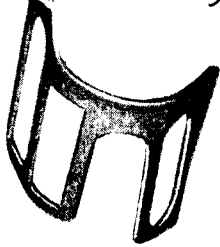
36820



196



36818



50316



36819

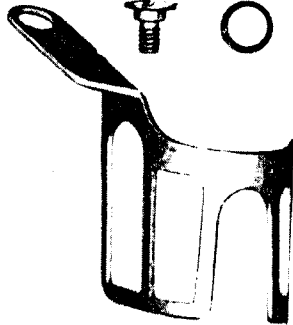
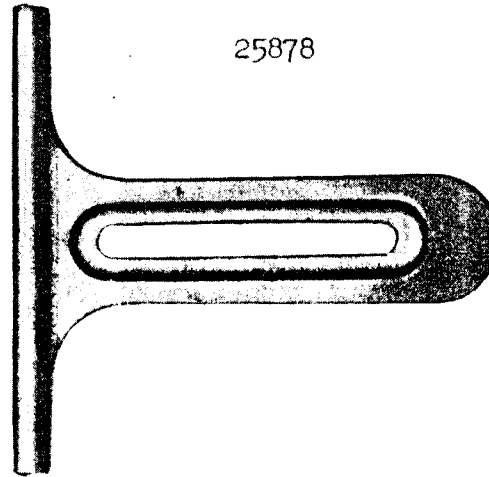


PLATE 6449 - FULL SIZE

25878



25866

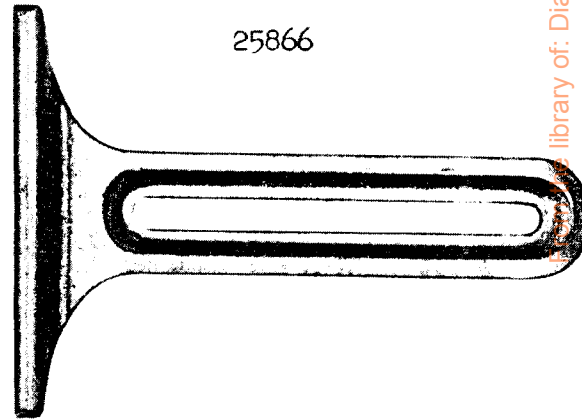


PLATE 7233—ONE-FOURTH SIZE

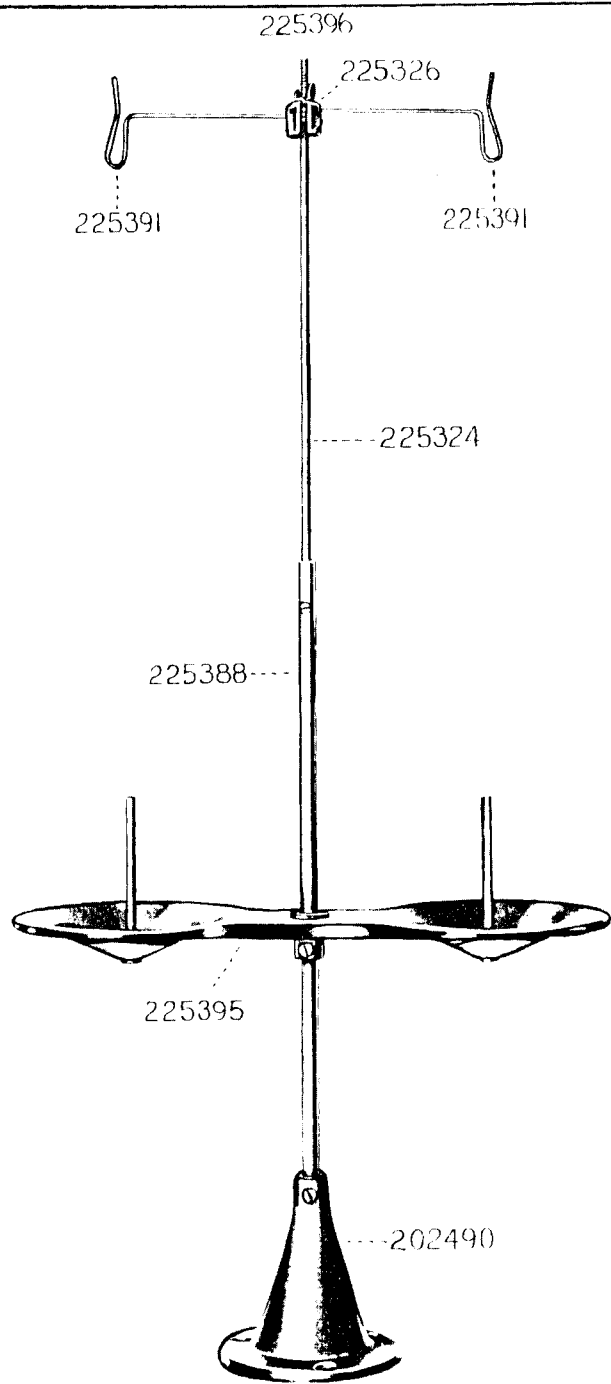
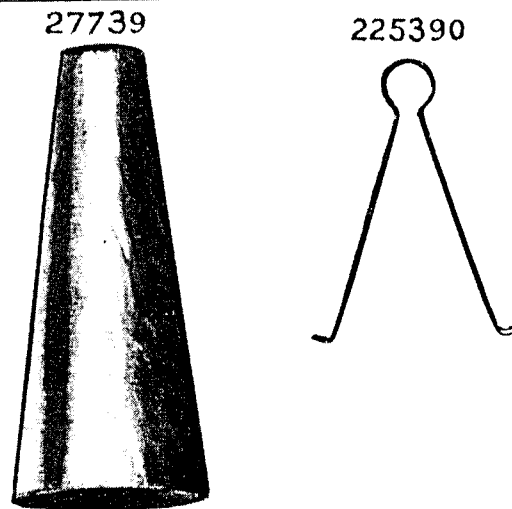


PLATE 7234—ONE-HALF SIZE



From the library of: Diamond Needle Corp

PLATE 20335 - ONE-SIXTH SIZE

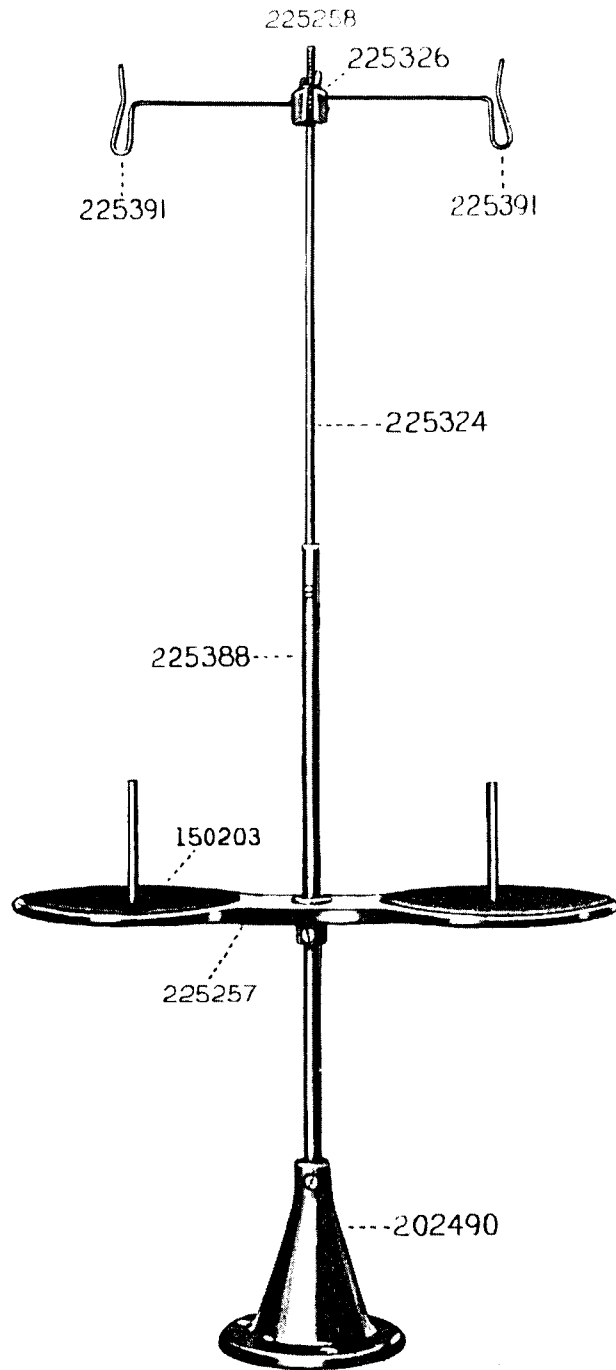
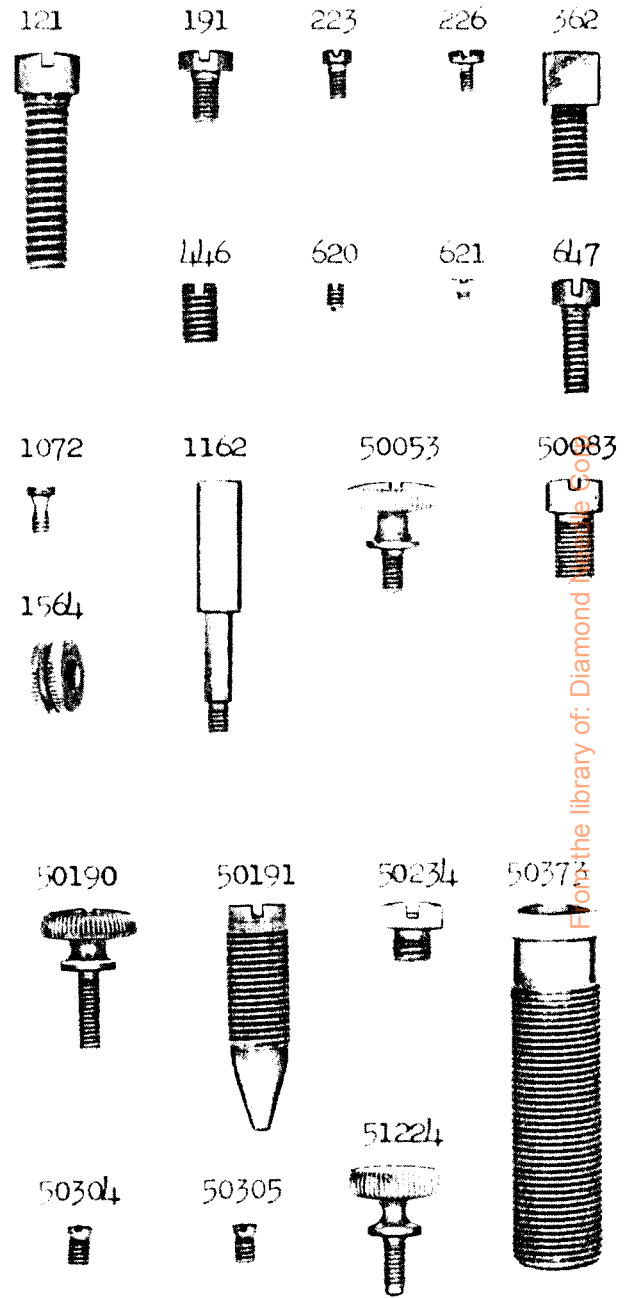


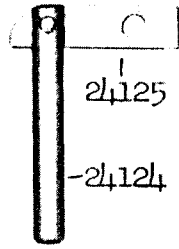
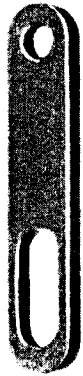
PLATE 21855 - FULL SIZE



From the library of: Diamond State Co.

PLATE 21856 - FULL SIZE

24122 12240 12241 24906



24125

-24124

27660



2523



2301



11833



132590



56006



7958



2022



54897



2291



210958



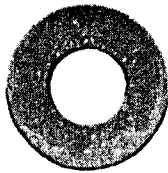
210993



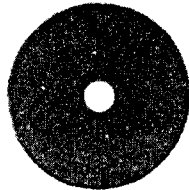
2297



25446



8879



2103

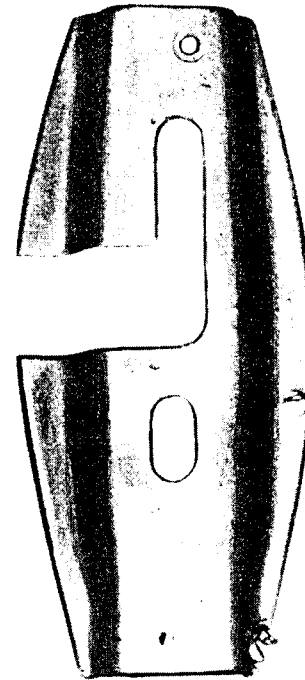


PLATE 21857 - ONE-HALF SIZE

16585

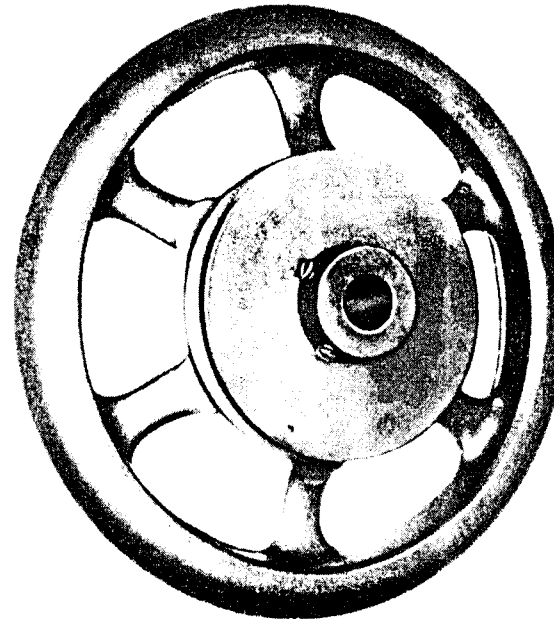


52103



52081

52101



From the Library of: Eastman-Kodak Company

PLATE 21858 - FULL SIZE

52120



52084



24123



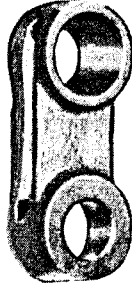
56015



52110



52165



5726



52073



2762



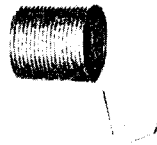
52114



52378



52082



52171



52170



52053

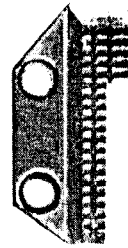


52398

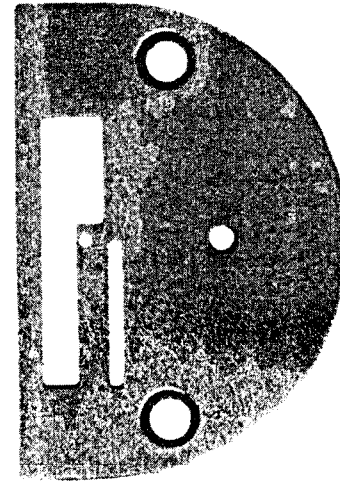


PLATE 21859 - FULL SIZE

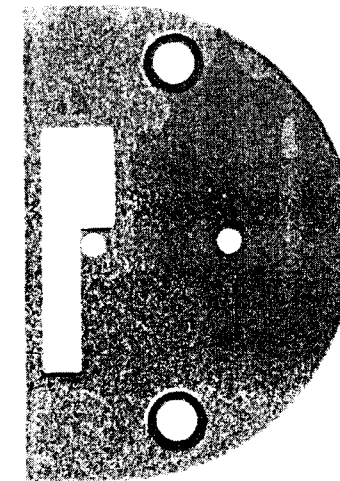
36525



36526



12411



From the library of: Diamond Needle Corp

PLATE 21860 - FULL SIZE

20150



20342



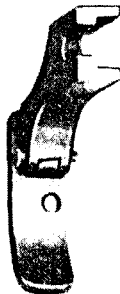
52056



24983



40318



52036



36119



35682

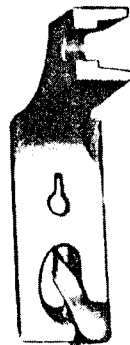
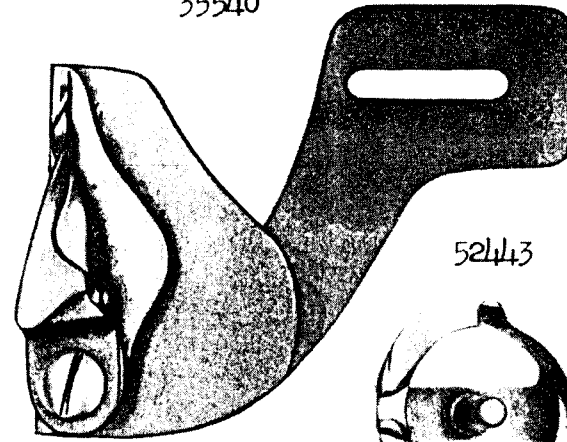


PLATE 21861 - FULL SIZE

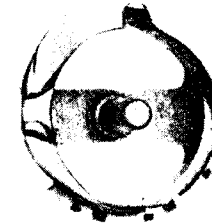
35245



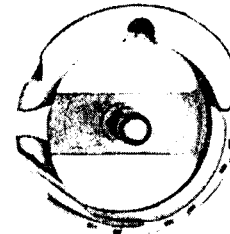
35540



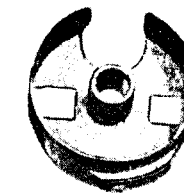
52443



127242



52236



125320



62527



From the library of: Diamond Needle Corp

PLATE 21862 - FULL SIZE

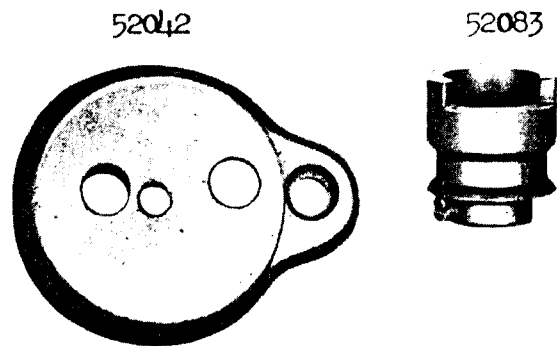
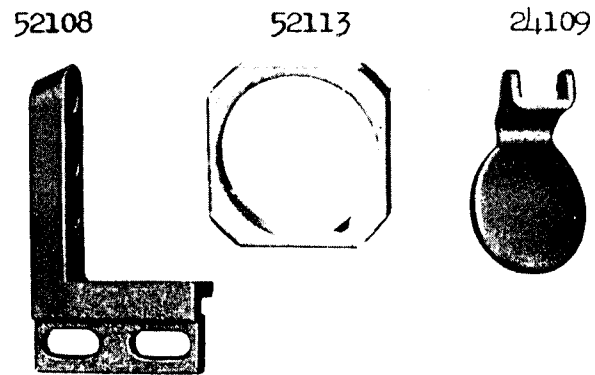
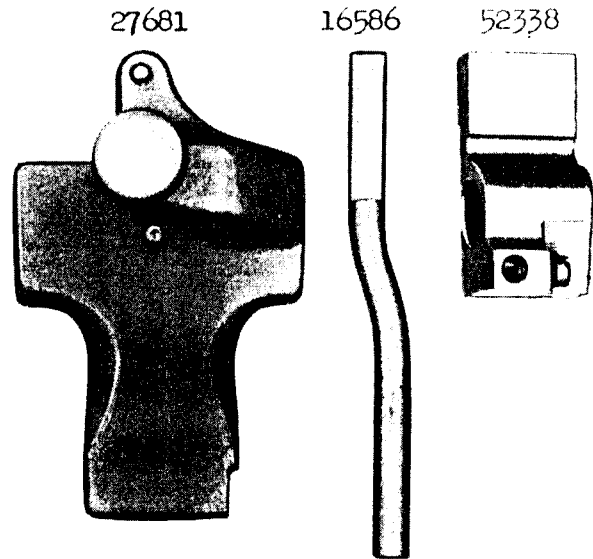
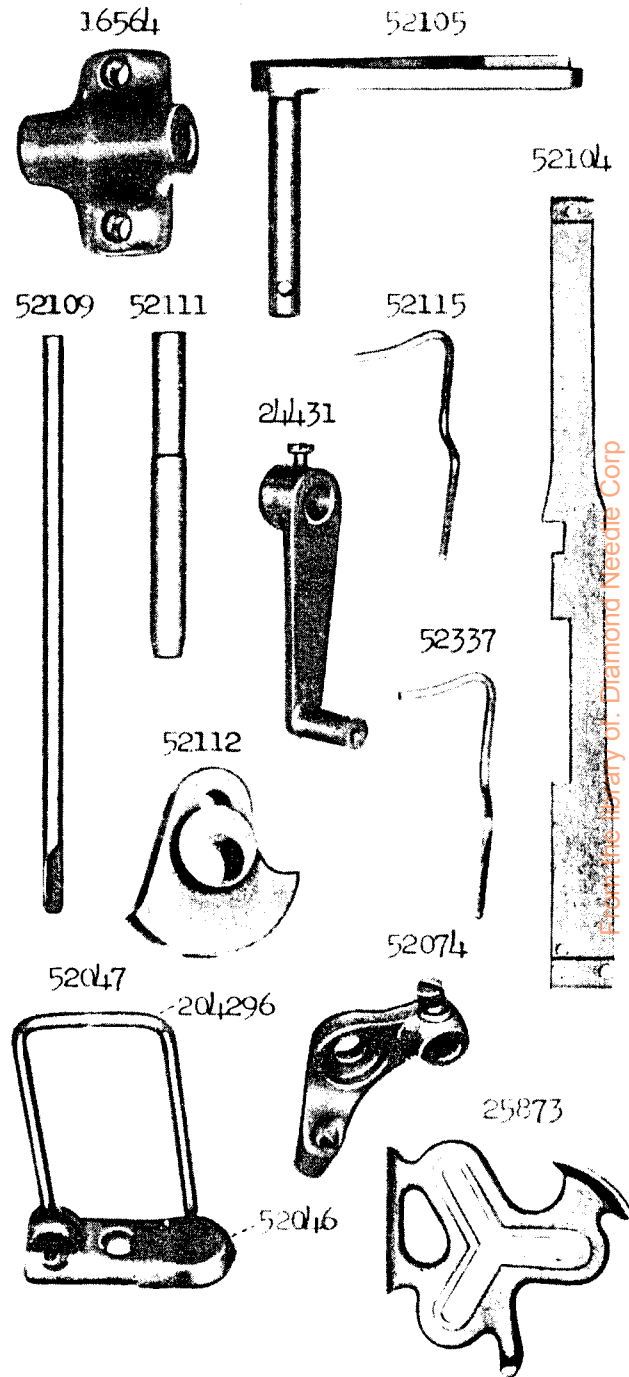


PLATE 21863 - ONE-HALF SIZE



From the library of: Diamond Needle Corp